

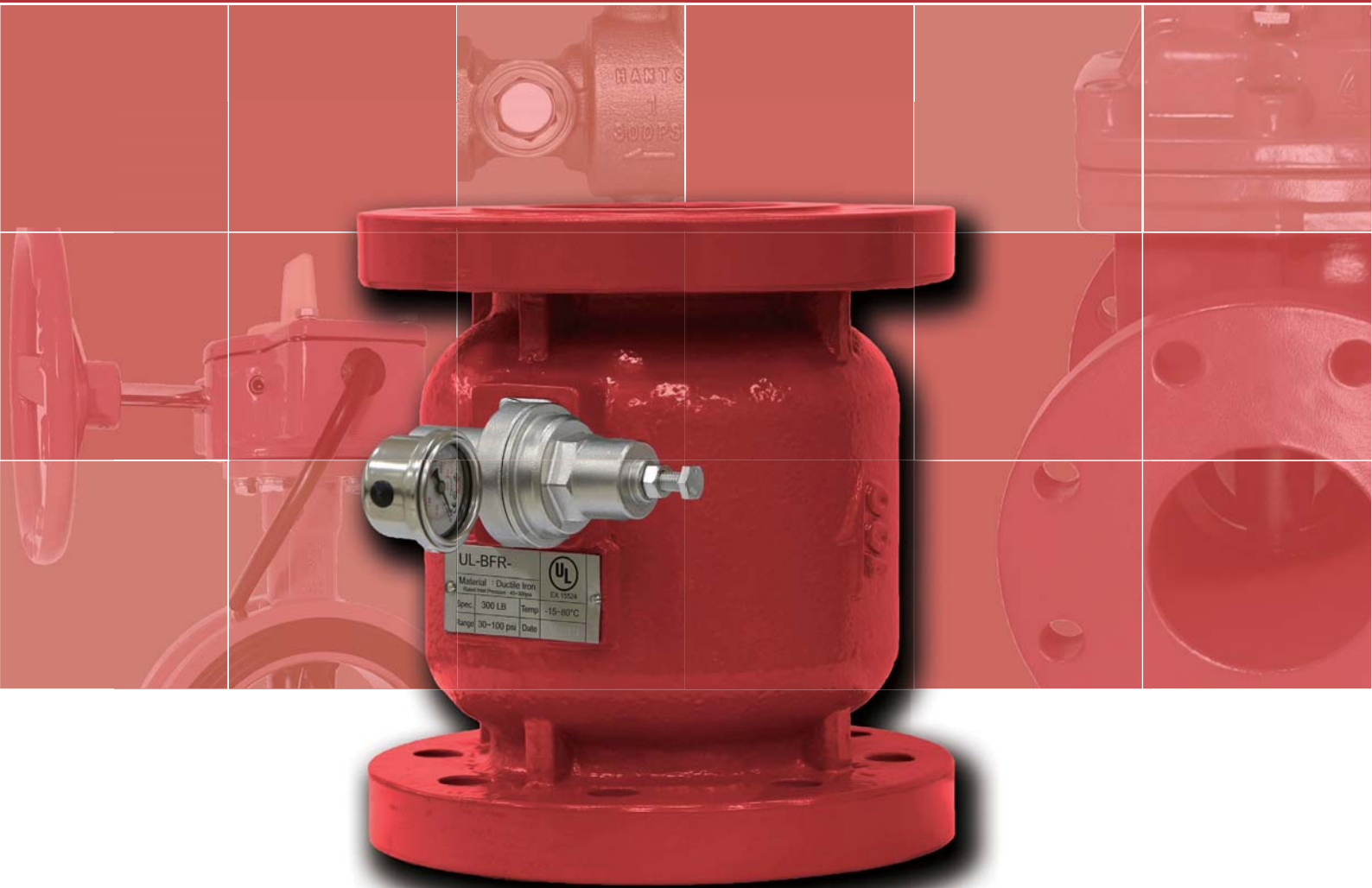

UL FIRE PROTECTION PRODUCTS



UL-BFR

series



UL PRESSURE REDUCING VALVE

- Applicative units for: Hose station Feeds, Sprinkler systems, Deluge system, Foam system, Fire hydrant water supply.
- Size: 3"(DN75) to 8"(DN200)
- Working Pressure:
 - Class#300 = 300 PSI (21BAR)
 - Class#150 = 250 PSI (17BAR)
- Adjust Range: 30~100 PSI (2 - 7 BAR)
- Test Pressure: 600/500 PSI
- Working Temp.: 0°C to 80°C (32°F to 176°F)
- Valve Standard: Original Design
- Connection Standard: ANSI B16.42 Class150
- Test Standard: UL 1739



UL-BFR

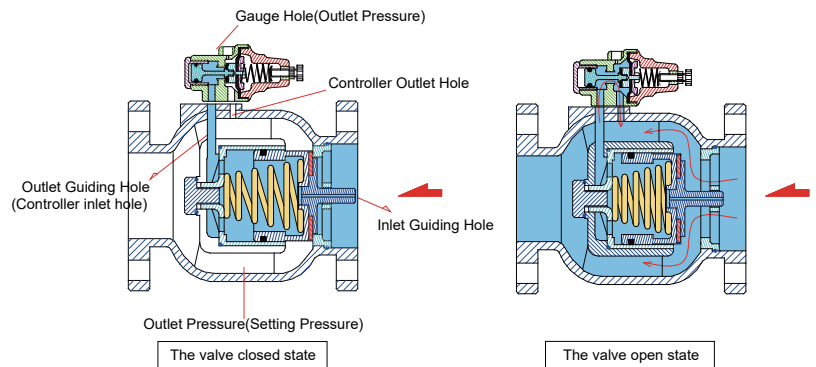
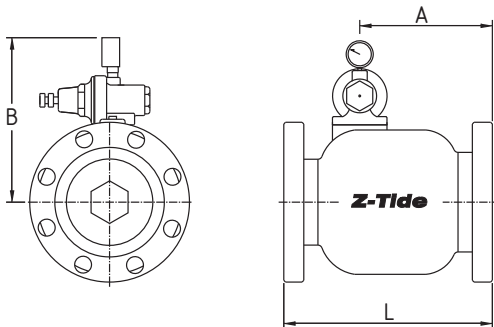
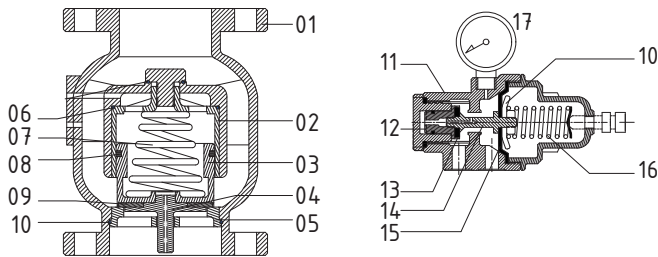

ITEM	PARTS	MATERIAL
1	MAIN BODY	DUCTILE IRON
2	CYLINDER	BRONZE
3	PISTON	BRONZE
4	SHAFT	BRONZE
5	SEAT	BRONZE
6	O-RING	NBR
7	SPRING	STAINLESS STEEL
8	U-RING	NBR
9	SEALING	NBR
10	O-RING	NBR
11	PILOT MAIN BODY	STAINLESS STEEL
12	PILOT PLUG	STAINLESS STEEL
13	PILOT SEALING	NBR
14	PILOT SHAFT	STAINLESS STEEL
15	PILOT DIAPHRAGM	EPDM
16	PILOT SPRING	SPRING STEEL
17	PRESSURE GAUGE	STAINLESS STEEL

SIZES		DIMENSIONS (MM)					
Inch	mm	A	B	L	Weight(kg)	Max. Flow(GPM)	
3"	DN 75	152	205	240	24	400	
4"	DN 100	174	220	270	37	600	
6"	DN 150	208	255	335	63	1500	
8"	DN 200	296	295	450	112	3200	

HHY

series



Dry Barrel Fire Hydrant

- Working Pressure: 250 PSI
- Connection:
 Mechanical Type (ANSI/AWWA C153/A21.536)
 Flanged Type (ASME B16.5 CLASS 150/DIN 2501 PN16)
 2 x 2½" NH thread connectors for soft hose connection.
 1 x 4½" NH thread pumper connection for fire trucks.
- Dry barrel design eliminates damage to the hydrant caused by freezing of the upper part.
- Main valve is easily removed from either the ground line flange.

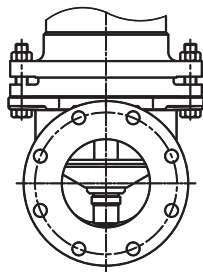
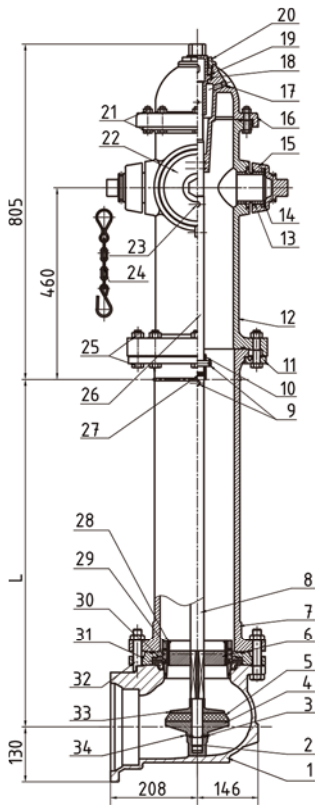

HHY-250FF

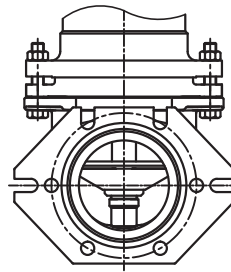

HHY-250MJ

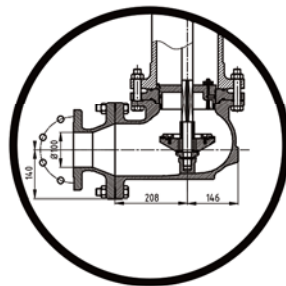

ITEM	PARTS	MATERIAL
1	BODY	DUCTILE IRON
2	SEAT	ASTM-C95400
3	HOSE NOZZLE	BRONZE
4	OPERATING NUT	BRONZE
5	PUMP NOZZLE	BRONZE
6	BONNET	DUCTILE IRON
7	STEM	CARBON STEEL

SIZES		DIMENSIONS (MM)					
Inch	mm	WAY	PUMPER OUTLET	HOSE OUTLET	BURIED DEPTH	WORKING PRESSURE	WEIGHT
4" / 6"	DN 100 / 150	3	4½" NH thread	2 x 2½" NH thread	1063	250 PSI	176 KG
4" / 6"	DN 100 / 150	3	4½" NH thread	2 x 2½" NH thread	1215	250 PSI	183 KG
4" / 6"	DN 100 / 150	3	4½" NH thread	2 x 2½" NH thread	1368	250 PSI	201 KG
4" / 6"	DN 100 / 150	3	4½" NH thread	2 x 2½" NH thread	1520	250 PSI	203 KG
4" / 6"	DN 100 / 150	3	4½" NH thread	2 x 2½" NH thread	1673	250 PSI	210 KG
4" / 6"	DN 100 / 150	3	4½" NH thread	2 x 2½" NH thread	1825	250 PSI	218 KG
4" / 6"	DN 100 / 150	3	4½" NH thread	2 x 2½" NH thread	1978	250 PSI	226 KG
4" / 6"	DN 100 / 150	3	4½" NH thread	2 x 2½" NH thread	2130	250 PSI	235 KG

HTD

series



TEST AND DRAIN VALVE

- Applicative units for: Test water flow through fire systems
- Working Pressure: 300 PSI (20.6 bar)
- Working Temp.: -10°C to 120°C (14°F to 250°F)
- Connection: Threaded NPT, BSPT, Grooved AWWA C606
- Three position ball valve OFF / TEST / DRAIN.
- Tamper-Resistant Test Orifice and Sight Glasses Compact.

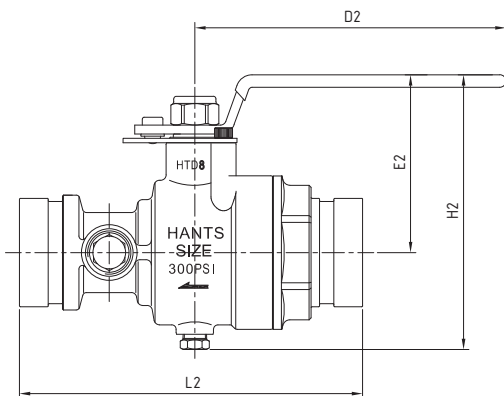
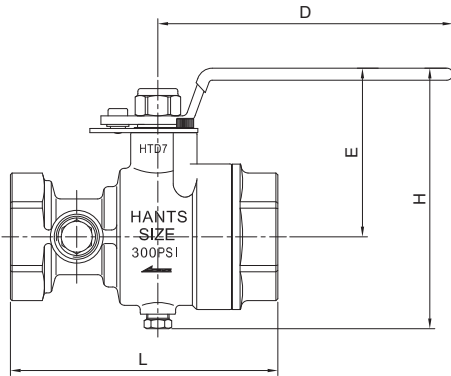

HTD7

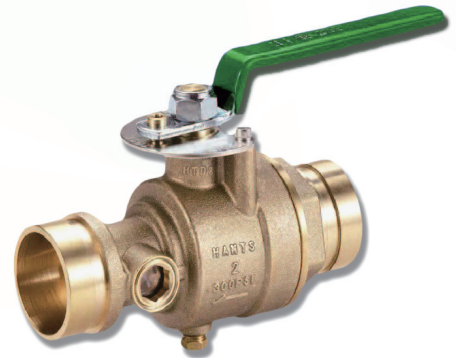

HTD8

ITEM	PARTS	MATERIAL
1	BODY	BRASS
2	SEAT	TFM
3	STEM	BRASS
4	STEM SEAL	TFM
5	BALL	BRASS
6	LEVER	STEEL
7	INDICATOR PLATE	STEEL

SIZES		DIMENSIONS (MM)									
Inch	mm	L	L2	H	H2	E	E2	D	D2	ORIFICE	K
1"	DN 25	128	161.6	113	112	68	68	130	130	7/16"/ 1/2"	4.2/ 5.6
1.25"	DN 32	128	161.6	113	112	68	68	130	130	7/16"/ 1/2"	4.2/ 5.6
1.5"	DN 40	157	190.9	155	155	99	99	157	157	7/16"/ 1/2"/ 3/4"/ 3/4"	4.2/ 5.6/ 14/ 25
2"	DN 50	157	190.9	155	155	99	99	157	157	7/16"/ 1/2"/ 3/4"/ 3/4"	4.2/ 5.6/ 14/ 25

HBS

series



UL Signal Butterfly Valve

Working Pressure : 300PSI / 20.7Bar

Connection: 1"~2.5" Theraded end



HBS-300G
HBS-300S

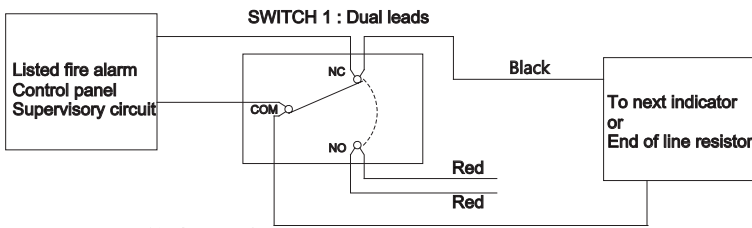
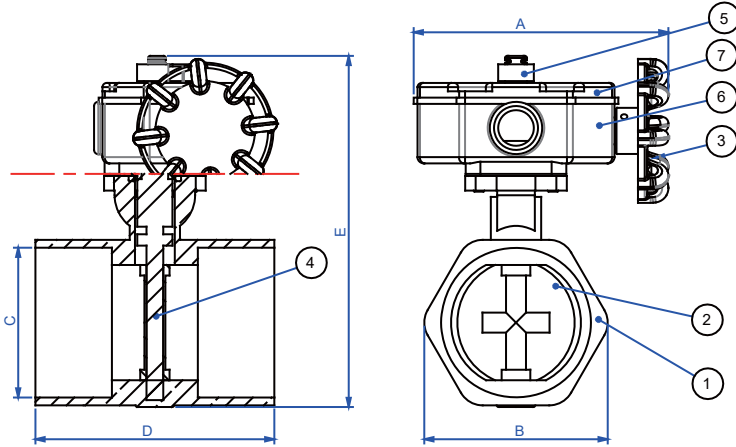

Switch Rating : 10 AMP / 115 VAC
5 AMP / 28 VDC

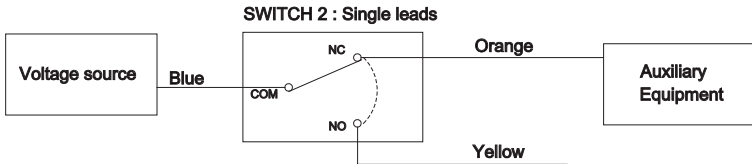

ITEM	PARTS	MATERIAL
1	BODY	BRONZE
2	DISC	SS304
3	HANDWHEEL	WCB
4	SEAT	VITOM
5	INDICATOR	POWDER METALLURGY
6	HOUSING	BRASS
7	COVER	BRASS

SIZES		DIMENSIONS (MM)				
Inch	mm	A	B	C(BSPT Thread)	D	E
1"	DN 25	120	44.5	1"	54	126
1.25"	DN 32	120	55	1 1/4"	66.7	130
1.5"	DN 40	120	60	1 1/2"	73	142
2"	DN 50	120	79	2"	82.6	156
2.5"	DN 65	120	96	2 1/2"	114	168

HRA

series



Pressure Reducing Angle Valve

- Applicative units for: Used With A Fire Hose Rack Assembly.
- Working Pressure: 175 PSI (12.06 bar)
- Working Temp.: -10°C to 80°C (14°F to 176°F)
- Connection: HRA-175: NPT inlet (F) x NPT outlet (F)
HRA-175S: NPT inlet (F) x NST outlet (M)
- Water Pressure Is Controlled By Adjustable Flow Restriction.
- Locking Pin Device Restricts Full Opening Of Valve By Untrained Personnel.



HRA-175
HRA-175S

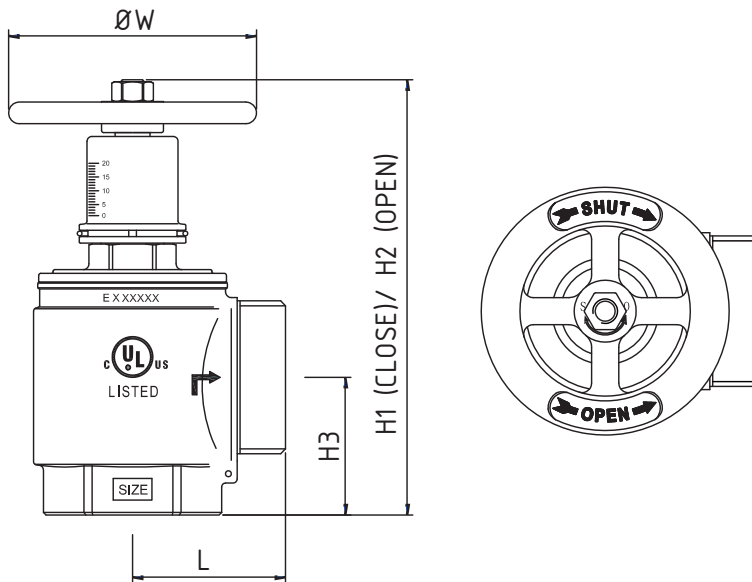

ITEM	PARTS	MATERIAL
1	BODY	BRASS
2	SEAT	NBR
3	BONNET	BRASS
4	INSTRUMENT	BRASS
5	STEM	BRASS
6	DISC HOLDER	BRASS
7	CLAMPING RING	BRASS
8	O-RING	NBR
9	NUT	SS
10	INDICATOR	BRASS
11	NAME PLATE	ALUMINUM

SIZES		DIMENSIONS (MM)					CONNECTION
Inch	mm	L1	H2	H3	L	ØW	
1-1/2"	DN 40	162.5	189	50	58.1	90	NPT inlet (F) x NPT outlet (F)
2-1/2"	DN 65	221	271	70	79	127	NPT inlet (F) x NPT outlet (F)
1-1/2"	DN 40	162.5	189	50	58.1	90	NPT inlet (F) x NST outlet (M)
2-1/2"	DN 65	221	271	70	79	127	NPT inlet (F) x NST outlet (M)

HWD

series



PREPARATION

Waterflow Detector with Retard – U Bolted

- Service Pressure: Up to 450PSI (3.1MPa)
- Flow Sensitivity Range for Signal: 4-10GPM (15.0-37.5L/min)
- Maximum Surge: 18FPS (5.5m/s)
- Contact Ratings: Two sets of SPDT
 - 10.1Amps at 125/250 VAC
 - 2.0Amps at 24 VDC
- Operating Temperature Range: 40° F to 120°F (4.5°C to 49°C)
- Enclosure Rating: NEMA 4- suitable for indoor/outdoor use
- Conduit Entrances: Two opening for 1/2" conduit
 - One open, one knock-out type
- Compatible Pipe: Steel water pipe, schedule 10 through 40
- Service Use: Automatic Sprinkler: NFPA-13
- One or Two Family Dwelling: NFPA-13D
- Residential Occupancies up to 4 stories: NFPA-13R
- National Fire Alarm Code: NFPA-72
- Warranty: 3 Years



HWD-450U

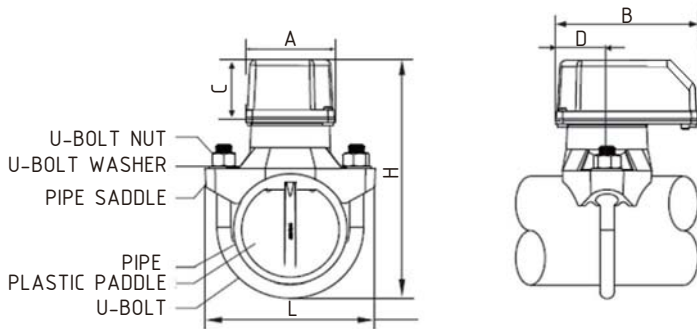
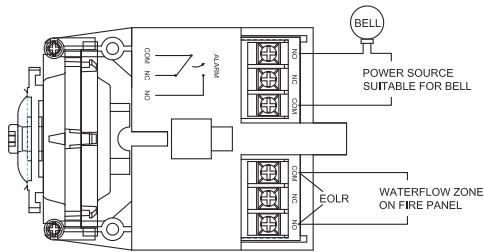

ITEM	PARTS	MATERIAL
1	SADDLE	ALUMINUM ADC12
2	PLATE	ALUMINUM ADC12
3	COVER	PLASTIC
4	PADDLE	PLASTIC
5	MICROSWITCH	PLASTIC
6	GASKET	EPDM
7	RETARD DEVICE	PLASTIC
8	TERMINAL BLOCK	PLASTIC

SIZES		DIMENSIONS (MM)						
Inch	mm	L	H	A	B	C	D	WEIGHT(KG)
2"	DN 50	94.5	165.8	95.25	146.56	55.88	72.39	1.35
2.5"	DN 65	109.5	180.8	95.25	146.56	55.88	72.39	1.35
3"	DN 80	134	195.8	95.25	146.56	55.88	72.39	1.4
4"	DN 100	154	215.8	95.25	146.56	55.88	72.39	1.45
6"	DN 150	204	265.8	95.25	146.56	55.88	72.39	1.85
8"	DN 200	254	315.8	95.25	146.56	55.88	72.39	2.42

HAG

series



HOSE ANGLE VALVE

- Body Material : Brass
- Applicative Units for:
Test Water Flow Through Fire Systems
- Working Temp.: -10°C to 80°C (14°F to 176°F)
- Working Pressure: 300 PSI
- Connection: Threaded NPT, Grooved
- Size range: 1-1/2, 2-1/2



HAG-300

HGT1

series



HGT1-175

BRONZE GATE VALVE

- Body Material : Bronze
- Applicative Units for:
Test Water Flow Through Fire Systems
- Working Temp.: -10°C to 80°C (14°F to 176°F)
- Working Pressure: 175 PSI
- Connection: Threaded NPT
- Size range: 3/4", 1", 1-1/4", 1-1/2", 2"

HBF

series



UL Butterfly Valve – Grooved Ends

- Size: 2"(DN50) to 12"(DN300)
- Working Pressure: 300 PSI
- Test Pressure: 600 PSI
- Working Temp.: 0°C to 80°C (32°F to 176°F)
- Valve Standard: UL1091&ULC/ORD-C1091
- Top Flange Standard: ISO 5211
- Connection Standard: ANSI/AWWA C606
- Test Standard: UL1091&ULC/ORD-C1091



HBF-300G

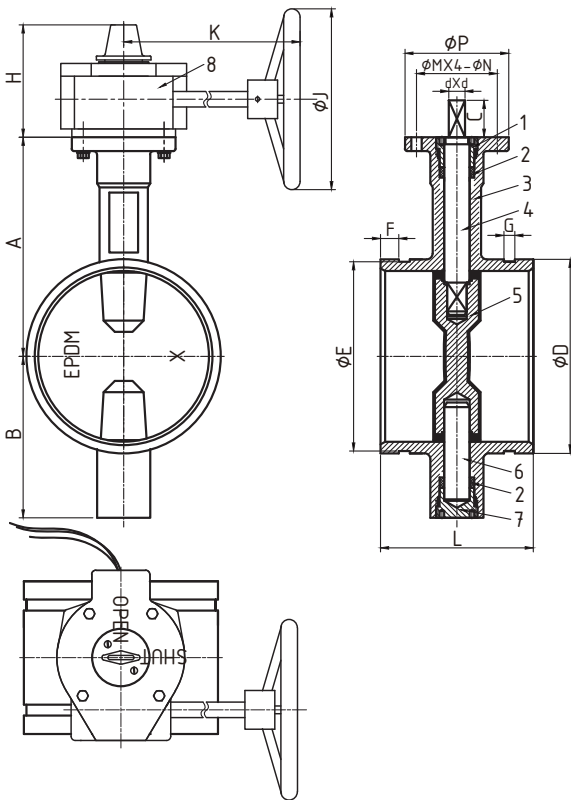

ITEM	PARTS	MATERIAL
1	UPPER SHAFT SEALING NUT	WCB
2	SHAFT SEAL	EPDM
3	BODY	DI
4	UPPER SHAFT	SS416
5	DISC	DI+EPDM
6	LOWER SHAFT	SS416
7	LOWER SHAFT SEALING NUT	WCB
8	SIGNAL GEARBOX	DI

SIZES		DIMENSIONS (MM)														
Inch	mm	A	B	C	D	E	F	G	H	K	J	P	M	N	d	L
2.5"	DN 65	125	95	32	76.1	72.1	15.9	7.9	111	234	152	90	70	9	10	96.4
3"	DN 80	140	100	32	88.9	84.9	15.9	7.9	111	234	152	90	70	9	11	97
4"	DN 100	160	100	32	114.3	110.1	15.9	9.5	111	234	152	90	70	9	14	115.1
5"	DN 125	170	125	32	141.3	137	15.9	9.5	111	234	152	90	70	9	14	132.4
6"	DN 150	190	140	32	168.3	164	15.9	9.5	111	234	200	90	70	9	16	132.4
8"	DN 200	230	175	32	219.1	214.6	19	11.1	126	230	290	125	102	12	19	147.4
10"	DN 250	260	200	45	273	268.3	19	12.7	126	230	290	125	102	12	22	159
12"	DN 300	300	240	45	324	318.3	19	12.7	161	249	350	150	125	14	24	165

HBF

series



UL Butterfly Valve – Wafer Ends

- Size: 2"(DN50) to 12"(DN300)
- Working Pressure: 300 PSI
- Test Pressure: 600 PSI
- Working Temp.: 0°C to 80°C (32°F to 176°F)
- Valve Standard: UL1091&ULC/ORD-C1091
- Top Flange Standard: ISO 5211
- Connection Standard: ASME B16.1
- Test Standard: UL1091&ULC/ORD-C1091



HBF-300W

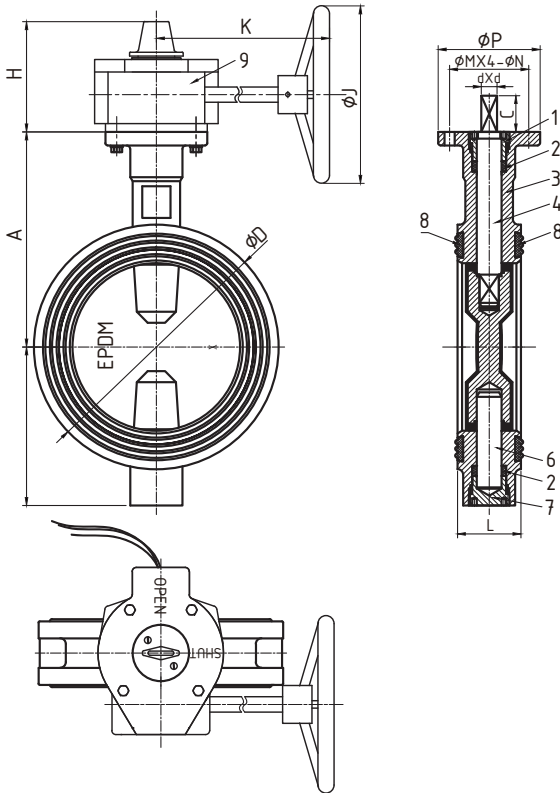

ITEM	PARTS	MATERIAL
1	UPPER SHAFT SEALING NUT	WCB
2	SHAFT SEAL	EPDM
3	BODY	DI
4	UPPER SHAFT	SS416
5	DISC	DI+EPDM
6	LOWER SHAFT	SS416
7	LOWER SHAFT SEALING NUT	WCB
8	END FACE SEAL	EPDM
9	SIGNAL GEARBOX	DI

SIZES		DIMENSIONS (MM)											
Inch	mm	A	B	C	D	H	K	J	P	M	N	d	L
2.5"	DN 65	125	95	32	112	111	234	152	90	70	9	10	44.2
3"	DN 80	140	100	32	120	111	234	152	90	70	9	11	45.3
4"	DN 100	160	100	32	165	111	234	152	90	70	9	14	52
5"	DN 125	170	125	32	182	111	234	152	90	70	9	14	54.4
6"	DN 150	190	140	32	216	111	234	200	90	70	9	16	55.8
8"	DN 200	230	175	32	260	126	230	290	125	102	12	19	60.5
10"	DN 250	260	200	45	320	126	230	290	125	102	12	22	66.5
12"	DN 300	300	240	45	375	161	249	350	150	125	14	24	76.9

HGN

series



UL NRS Gate Valve – Flange Ends

- Size: 2.5"(DN65) to 12"(DN300)
- Working Pressure: 200 PSI
- Test Pressure: 400 PSI
- Working Temp.: 0°C to 80°C (32°F to 176°F)
- Valve Standard: UL262,ULC/ORD C262-92
- Connection Standard:
ASME/ANSI B16.1 Class 125 or
ASME/ANSI B16.42 Class 150 or
BS EN1092-2 PN16 or GB/T9113.1
- Test Standard: UL262,ULC/ORD C262-92



HGN-200FF

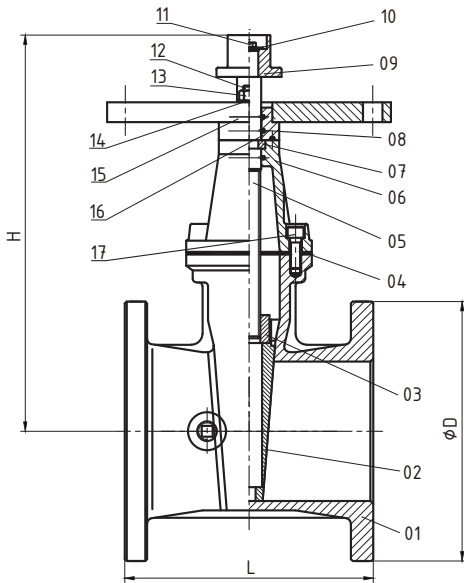

ITEM	PARTS	MATERIAL
1	BODY	DI, ASTM A536 GRADE65-45-12
2	DISC	DI, ASTM A536 GRADE65-45-12 + EPDM,ASTM D2000
3	NUT	C95400.ASTM B148
4	GASKET	EPDM.ASTM D2000
5	STEM	S.S.304.ASTM A276
6	CAP	DI, ASTM A536 GRADE65-45-12
7	RETAINER RING	C95400.ASTM B148
8	O-RING	EPDM,ASTM D2000
9	WRENCH NUT	DI, ASTM A536 GRADE65-45-12
10	MINIPAD	1045,ASTM A29
11	BOLT	1045,ASTM A29
12	STUD	1045,ASTM A29
13	NUT	1045.ASTM A29
14	FLAT WASHER	1045,ASTM A29
15	COUPLING FLANGE	DI, ASTM A536 GRADE65-45-12
16	PLATEN	DI, ASTM A536 GRADE65-45-12
17	COUNTERSUNK HEAD BOLT	1045, ASTM A29

SIZES		DIMENSIONS (MM)		
Inch	mm	L	H	φD
2"	DN 50	178	265	152
2-1/2"	DN 65	190	289	178
3"	DN 80	203	326	190
4"	DN 100	229	355	229
5"	DN 125	254	410	254
6"	DN 150	267	455	279
8"	DN 200	292	558	343
10"	DN 250	330	648	406
12"	DN 300	356	745	483

HGN

series



UL NRS Gate Valve – Grooved & Flange Ends

- Size: 2.5"(DN65) to 12"(DN300)
- Working Pressure: 200 PSI
- Test Pressure: 400 PSI
- Working Temp.: 0°C to 80°C (32°F to 176°F)
- Valve Standard: UL262,ULC/ORD C262-92
- Connection Standard:
 - Flange: ASME/ANSI B16.1 Class 125 or ASME/ANSI B16.42 Class 150 or BS EN1092-2 PN16 or GB/T9113.1
 - Grooved: ANSI/AWWA C606
- Face to Face Standard: ASME B16.10
- Test Standard: UL262,ULC/ORD C262-92



HGN-200FG

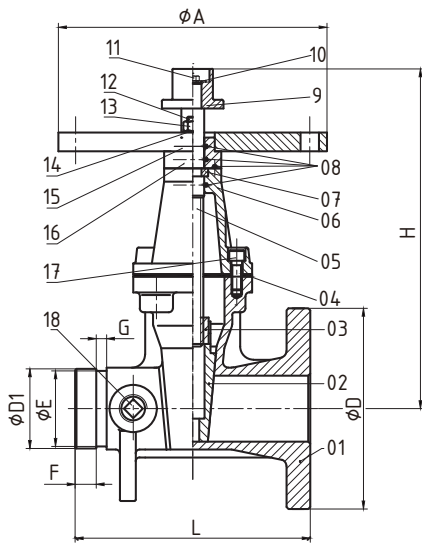

ITEM	PARTS	MATERIAL
1	BODY	DI ASTM A536 65-45-12
2	DISC	DI+EPDM ASTM A536 65-45-12 + EPDM
3	NUT	C95400 ASTM B148
4	GASKET	EPDM ASTM D2000 EPDM
5	STEM	S. S. 304 ASTM A276
6	CAP	DI ASTM A536 65-45-12
7	RETAINER RING	C95400 ASTM B148
8	O-RING	EPDM ASTM D2000 EPDM
9	SCOTCH	DI ASTM A536 65-45-12
10	MINIPAD	STEEL
11	BOLT	STEEL
12	BOLT STUD	STEEL
13	BLIND NUT	STEEL
14	PLAIN WASHER	STEEL
15	COUPLING FLANGE	DI ASTM A536 65-45-12
16	PLATEN	DI ASTM A536 65-45-12
17	COUNTERSUNK HEAD BOLT	STEEL
18	PLUG	C95400 ASTM B62

SIZES		DIMENSIONS (MM)						
Inch	mm	L	H	φD	φD1	φE	F	G
2-1/2"	DN 65	190	289	178	76.1	72.3	15.9	7.9
3"	DN 80	203	326	191	88.9	84.9	15.9	7.9
4"	DN 100	229	355	229	114.3	110.1	15.9	9.5
5"	DN 125	254	410	254	141.3	137	15.9	9.5
6"	DN 150	267	455	279	168.3	163.9	15.9	9.5
8"	DN 200	292	558	343	219.1	214.4	19	11.1
10"	DN 250	330	648	406	273	268.3	19	12.7
12"	DN 300	356	745	483	323.9	318.3	19	12.7

HGN

series



UL NRS Gate Valve – Grooved & Flange Ends

- Size: 2.5"(DN65) to 12"(DN300)
- Working Pressure: 200 PSI
- Test Pressure: 400 PSI
- Working Temp.: 0°C to 80°C (32°F to 176°F)
- Valve Standard: UL262,ULC/ORD C262-92
- Connection Standard: ANSI/AWWA C606
- Face to Face Standard: ASME B16.10
- Test Standard: UL262,ULC/ORD C262-92



HGN-200GG

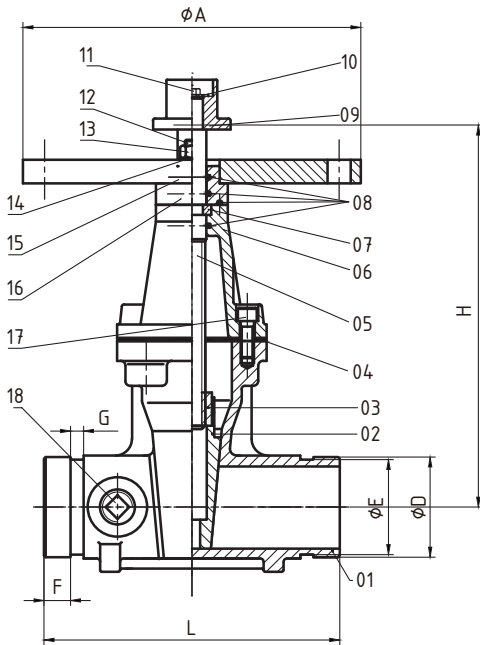

ITEM	PARTS	MATERIAL
1	BODY	DI ASTM A536 65-45-12
2	DISC	DI+EPDM ASTM A536 65-45-12 + EPDM
3	NUT	C95400 ASTM B148
4	GASKET	EPDM ASTM D2000 EPDM
5	STEM	S. S. 304 ASTM A276
6	CAP	DI ASTM A536 65-45-12
7	RETAINER RING	C95400 ASTM B148
8	O-RING	EPDM ASTM D2000 EPDM
9	SCOTCH	DI ASTM A536 65-45-12
10	MINIPAD	STEEL
11	BOLT	STEEL
12	BOLT STUD	STEEL
13	BLIND NUT	STEEL
14	PLAIN WASHER	STEEL
15	COUPLING FLANGE	DI ASTM A536 65-45-12
16	PLATEN	DI ASTM A536 65-45-12
17	COUNTERSUNK HEAD BOLT	STEEL
18	PLUG	CAST BRONZE ASTM B62

SIZES		DIMENSIONS (MM)						
Inch	mm	L	H	øD	øD1	øE	F	G
2-1/2"	DN 65	190	289	178	76.1	72.3	15.9	7.9
3"	DN 80	203	326	191	88.9	84.9	15.9	7.9
4"	DN 100	229	355	229	114.3	110.1	15.9	9.5
5"	DN 125	254	410	254	141.3	137	15.9	9.5
6"	DN 150	267	455	279	168.3	163.9	15.9	9.5
8"	DN 200	292	558	343	219.1	214.4	19	11.1
10"	DN 250	330	648	406	273	268.3	19	12.7
12"	DN 300	356	745	483	323.9	318.3	19	12.7

HGN

series



UL NRS Gate Valve – Flange Ends

- Size: 2.5"(DN65) to 12"(DN300)
- Working Pressure: 300 PSI
- Test Pressure: 600 PSI
- Working Temp.: 0°C to 80°C (32°F to 176°F)
- Valve Standard: UL262,ULC/ORD C262-92
- Connection Standard:
ASME/ANSI B16.1 Class 125 or
ASME/ANSI B16.42 Class 150 or
BS EN1092-2 PN16 or GB/T9113.1
- Face to Face Standard: ASME B16.10
- Test Standard: UL262,ULC/ORD C262-92



HGN-300FF

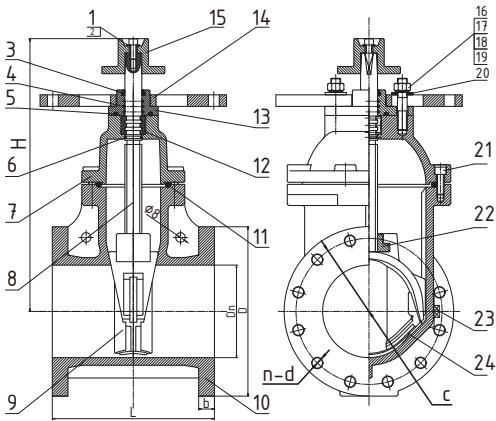

ITEM	PARTS	MATERIAL
1	FLAT WASHER	S. S. 304
2	INNER HEXAGON SCREW	S. S. 304
3	SEALING GLAND	EPDM
4	O-RING	EPDM
5	SEALING RING	EPDM
6	O-RING	EPDM
7	BONNET	DI
8	STEM	S. S. 304
9	DISC	EPDM+DI
10	BODY	DI
11	SEALING RING	EPDM
12	RETAINING RING	C954
13	GLAND	DI
14	TERMINAL PAD	DI
15	LINK BLOCK	DI
16	NUT	S. S. 304
17	STUDS	S. S. 304
18	SPRING WASHER	STEEL
19	WASHER	STEEL
20	WASHER	STEEL
21	INNER HEXAGON SCREW	STEEL
22	MASTERSCREW	C954
23	PLUG	C28000
24	SKELETON	DI

SIZES		DIMENSIONS (MM)					
Inch	mm	L	D	b	c	n-d	H
2.5"	DN 65	190	178	17.5	139.5	4-φ19	292
3"	DN 80	203	191	21	152.5	4-φ19	322
4"	DN 100	229	229	24	190.5	8-φ19	342
5"	DN 125	254	254	23.9	216	8-φ22	412
6"	DN 150	267	279	25.4	241.5	8-φ22	448
8"	DN 200	292	343	28.6	298.5	8-φ22	534
10"	DN 250	330	406	30.2	362	12-φ25	635
12"	DN 300	356	483	31.8	432	12-φ25	720

HGN

series



UL NRS Gate Valve – Flange & Grooved Ends

- Size: 2.5"(DN65) to 12"(DN300)
- Working Pressure: 300 PSI
- Test Pressure: 600 PSI
- Working Temp.: 0°C to 80°C (32°F to 176°F)
- Valve Standard: AWWA C515
- Connection Standard:
 - Flange: ASME/ANSI B16.1 Class 125 or ASME/ANSI B16.42 Class 150 or BS EN1092-2 PN16 or GB/T9113.1
 - Grooved: ANSI/AWWA C606
- Face to Face Standard: ASME B16.10
- Test Standard: UL262,ULC/ORD C262-92



HGN-300FG

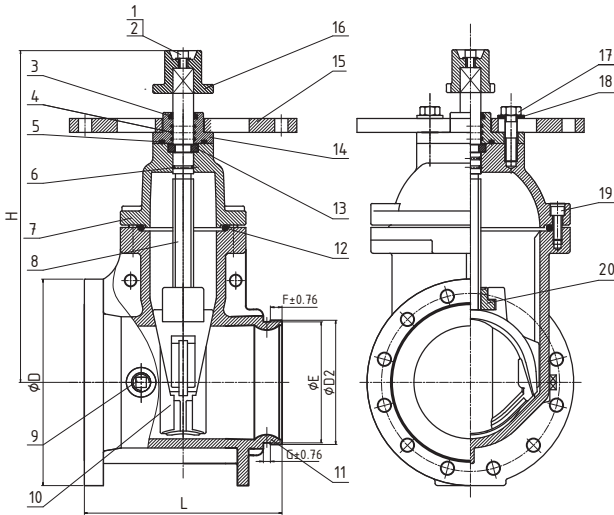

ITEM	PARTS	MATERIAL
1	FLAT WASHER	S.S.304, ASTM A276 OR 1045, ASTM A29
2	HEXAGON SOCKET SCREW	S.S.304, ASTM A276 OR 1045, ASTM A29
3	SEALING RING	EPDM, ASTM D2000
4	O-RING	EPDM, ASTM D2000
5	SEALING RING	EPDM, ASTM D2000
6	O-RING	EPDM, ASTM D2000
7	BONNET	DI, ASTM A536 Grade 65-45-12
8	STEM	S.S.304, ASTM A276 OR C95400, ASTM B148
9	PLUG	S.S.304, ASTM A276 OR C95400, ASTM B148
10	DISC	EPDM, ASTM D2000+ASTM A536 Grade 65-45-12
11	BODY	DI, ASTM A536 Grade 65-45-12
12	SEALING RING	EPDM, ASTM D2000
13	RETAINING RING	C95400, ASTM B148
14	GLAND	DI, ASTM A536 Grade 65-45-12
15	POST FLANGE	DI, ASTM A536 Grade 65-45-12
16	WRENCH NUT	DI, ASTM A536 Grade 65-45-12
17	BOLT	S.S.304, ASTM A276 OR 1045, ASTM A29
18	WASHER	S.S.304, ASTM A276 OR 1045, ASTM A29
19	HEXAGON SOCKET SCREW	S.S.304, ASTM A276 OR 1045, ASTM A29
20	STEM NUT	CF8, ASTM A351 OR C95400, ASTM B148

SIZES		DIMENSIONS (MM)									
Inch	mm	L	D	F	D2		D2		G	H	
2.5"	DN 65	190	178	15.9	76	73	72.3	69.1	7.9	292	
3"	DN 80	203	191	15.9	88.9		84.9		7.9	322	
4"	DN 100	229	229	15.9	114.3		110.1		9.5	342	
5"	DN 125	254	254	15.9	141.3	139.7	137	135.5	9.5	412	
6"	DN 150	267	279	15.9	168.3	165.1	163.9	160.8	9.5	448	
8"	DN 200	292	343	19	219.1	216.3	214.3	211.6	11.1	534	
10"	DN 250	330	406	19	273		268.3		12.7	635	
12"	DN 300	356	483	19	323.9		318.3		12.7	720	

HGN

series



UL NRS Gate Valve – Flange & Mechanical Joint Ends

- Size: 2.5"(DN65) to 12"(DN300)
- Working Pressure: 300 PSI
- Test Pressure: 600 PSI
- Working Temp.: 0°C to 80°C (32°F to 176°F)
- Valve Standard: AWWA C515
- Connection Standard:
 - Flange: ASME/ANSI B16.1 Class 125 or ASME/ANSI B16.42 Class 150 or BS EN1092-2 PN16 or GB/T9113.1
 - Mechanical Joint: ANSI/AWWA C110 and ANSI/AWWA C153
- Face to Face Standard: ASME B16.10
- Test Standard: UL262,ULC/ORD C262-92



HGN-300FM

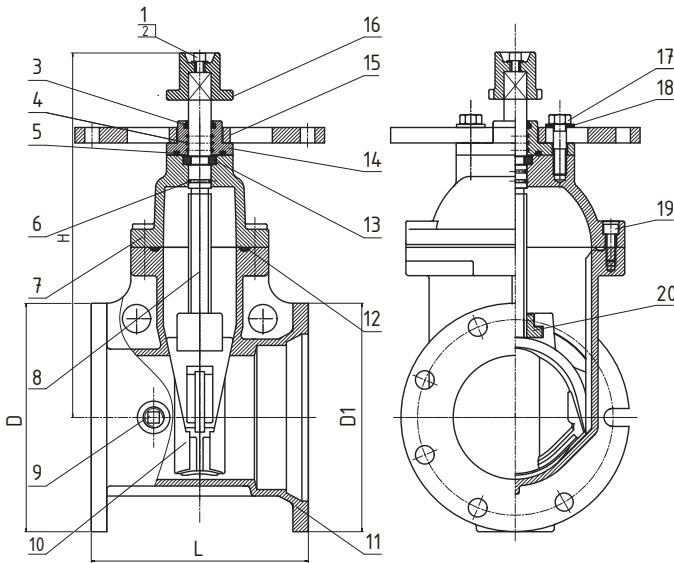

ITEM	PARTS	MATERIAL
1	FLAT WASHER	S.S.304, ASTM A276 OR 1045, ASTM A29
2	HEXAGON SOCKET SCREW	S.S.304, ASTM A276 OR 1045, ASTM A29
3	SEALING RING	EPDM, ASTM D2000
4	O-RING	EPDM, ASTM D2000
5	SEALING RING	EPDM, ASTM D2000
6	O-RING	EPDM, ASTM D2000
7	BONNET	DI, ASTM A536 Grade 65-45-12
8	STEM	S.S.304, ASTM A276 OR C95400, ASTM B148
9	PLUG	S.S.304, ASTM A276 OR C95400, ASTM B148
10	DISC	EPDM, ASTM D2000+ASTM A536 Grade 65-45-12
11	BODY	DI, ASTM A536 Grade 65-45-12
12	SEALING RING	EPDM, ASTM D2000
13	RETAINING RING	C95400, ASTM B148
14	GLAND	DI, ASTM A536 Grade 65-45-12
15	POST FLANGE	DI, ASTM A536 Grade 65-45-12
16	WRENCH NUT	DI, ASTM A536 Grade 65-45-12
17	BOLT	S.S.304, ASTM A276 OR 1045, ASTM A29
18	WASHER	S.S.304, ASTM A276 OR 1045, ASTM A29
19	HEXAGON SOCKET SCREW	S.S.304, ASTM A276 OR 1045, ASTM A29
20	STEM NUT	CF8, ASTM A351 OR C95400, ASTM B148

SIZES		DIMENSIONS (MM)			
Inch	mm	L	D	D1	H
3"	DN 80	203	191	195	322
4"	DN 100	229	229	232	342
6"	DN 150	267	279	282	448
8"	DN 200	292	343	340	534
10"	DN 250	330	406	399	635
12"	DN 300	356	483	456	720

HGN

series



UL NRS Gate Valve– Grooved Ends

- Size: 2.5"(DN50) to 12"(DN300)
- Working Pressure: 300 PSI
- Test Pressure: 600 PSI
- Working Temp.: 0°C to 80°C (32°F to 176°F)
- Valve Standard: AWWA C515
- Connection Standard: ANSI/AWWA C606
- Face to Face Standard: ASME B16.10
- Test Standard: UL262,ULC/ORD C262-92



HGN-300GG

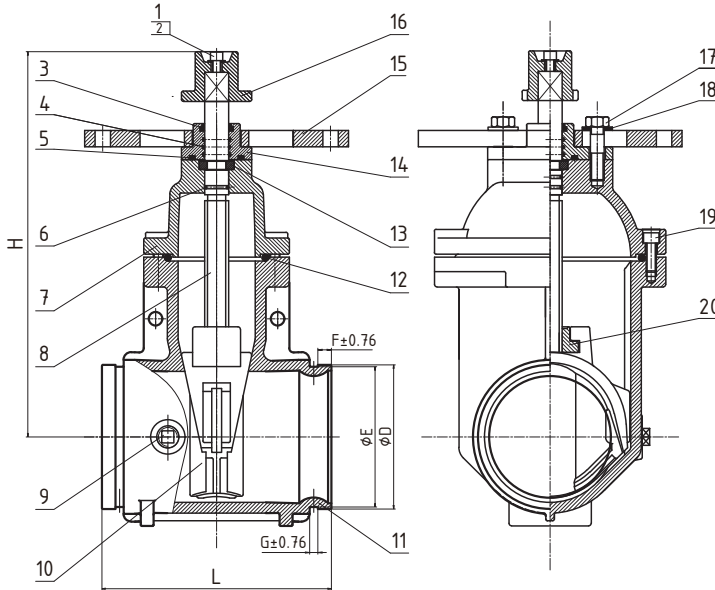

ITEM	PARTS	MATERIAL
1	FLAT WASHER	S.S.304, ASTM A276 OR 1045, ASTM A29
2	HEXAGON SOCKET SCREW	S.S.304, ASTM A276 OR 1045, ASTM A29
3	SEALING RING	EPDM, ASTM D2000
4	O-RING	EPDM, ASTM D2000
5	SEALING RING	EPDM, ASTM D2000
6	O-RING	EPDM, ASTM D2000
7	BONNET	DI, ASTM A536 Grade 65-45-12
8	STEM	S.S.304, ASTM A276 OR C95400, ASTM B148
9	PLUG	S.S.304, ASTM A276 OR C95400, ASTM B148
10	DISC	EPDM, ASTM D2000+ASTM A536 Grade 65-45-12
11	BODY	DI, ASTM A536 Grade 65-45-12
12	SEALING RING	EPDM, ASTM D2000
13	RETAINING RING	C95400, ASTM B148
14	GLAND	DI, ASTM A536 Grade 65-45-12
15	POST FLANGE	DI, ASTM A536 Grade 65-45-12
16	WRENCH NUT	DI, ASTM A536 Grade 65-45-12
17	BOLT	S.S.304, ASTM A276 OR 1045, ASTM A29
18	WASHER	S.S.304, ASTM A276 OR 1045, ASTM A29
19	HEXAGON SOCKET SCREW	S.S.304, ASTM A276 OR 1045, ASTM A29
20	STEM NUT	CF8, ASTM A351 OR C95400, ASTM B148

SIZES		DIMENSIONS (MM)								
Inch	mm	L	F	D		E		G	H	
2.5"	DN 65	190	15.9	76.1	73	72.3	69.1	7.9	292	
3"	DN 80	203	15.9	88.9		84.9		7.9	322	
4"	DN 100	229	15.9	114.3		110.1		9.5	342	
5"	DN 125	254	15.9	141.3	139.7	137	135.5	9.5	412	
6"	DN 150	267	15.9	168.3	165.1	163.9	160.8	9.5	448	
8"	DN 200	292	19	219.1	216.3	214.3	211.6	11.1	534	
10"	DN 250	330	19	273		268.3		12.7	635	
12"	DN 300	356	19	323.9		318.3		12.7	720	

HGN

series



UL NRS Gate Valve – Mechanical Joint & Mechanical Joint Ends

- Size: 2.5"(DN65) to 12"(DN300)
- Working Pressure: 300 PSI
- Test Pressure: 600 PSI
- Working Temp.: 0°C to 80°C (32°F to 176°F)
- Valve Standard: AWWA C515
- Connection Standard: ANSI/AWWA C110 and ANSI/AWWA C153
- Face to Face Standard: ASME B16.10
- Test Standard: UL262,ULC/ORD C262-92



HGN-300MM

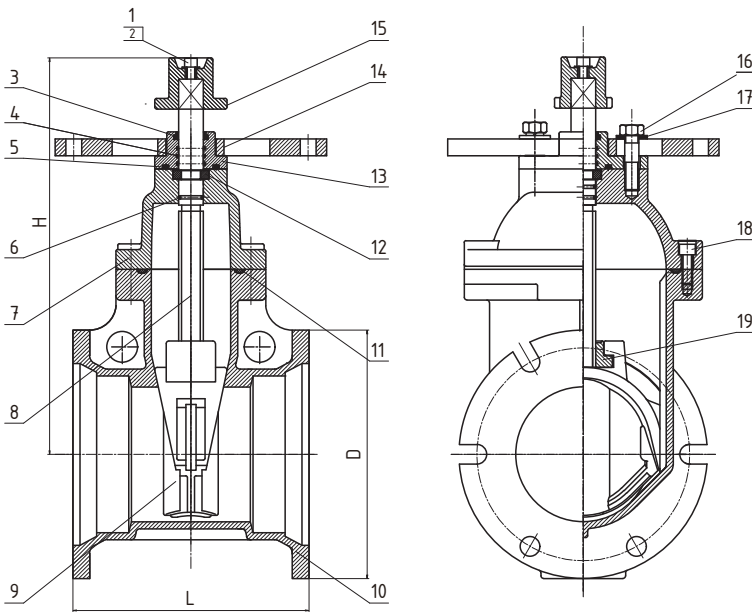

ITEM	PARTS	MATERIAL
1	FLAT WASHER	S.S.304, ASTM A276 OR 1045, ASTM A29
2	HEXAGON SOCKET SCREW	S.S.304, ASTM A276 OR 1045, ASTM A29
3	SEALING RING	EPDM, ASTM D2000
4	O-RING	EPDM, ASTM D2000
5	SEALING RING	EPDM, ASTM D2000
6	O-RING	EPDM, ASTM D2000
7	BONNET	DI, ASTM A536 Grade 65-45-12
8	STEM	S.S.304, ASTM A276 OR C95400, ASTM B148
9	DISC	EPDM, ASTM D2000+ASTM A536 Grade 65-45-12
10	BODY	DI, ASTM A536 Grade 65-45-12
11	SEALING RING	EPDM, ASTM D2000
12	RETAINING RING	C95400, ASTM B148
13	GLAND	DI, ASTM A536 Grade 65-45-12
14	POST FLANGE	DI, ASTM A536 Grade 65-45-12
15	WRENCH NUT	DI, ASTM A536 Grade 65-45-12
16	BOLT	S.S.304, ASTM A276 OR 1045, ASTM A29
17	WASHER	S.S.304, ASTM A276 OR 1045, ASTM A29
18	HEXAGON SOCKET SCREW	S.S.304, ASTM A276 OR 1045, ASTM A29
19	STEM NUT	CF8, ASTM A351 OR C95400, ASTM B148

SIZES		DIMENSIONS (MM)		
Inch	mm	L	D	H
3"	DN 80	203	195	322
4"	DN 100	229	232	342
6"	DN 150	267	282	448
8"	DN 200	292	340	534
10"	DN 250	330	456	635
12"	DN 300	356	499	720

HGO

series



UL O.S&Y Gate Valve – Flange Ends

- Size: 2"(DN50) to 12"(DN300)
- Working Pressure: 200 PSI
- Test Pressure: 400 PSI
- Working Temp.: 0°C to 80°C (32°F to 176°F)
- Valve Standard: UL262,ULC/ORD C262-92
- Connection Standard: ASME/ANSI B16.1 Class 125 or ASME/ANSI B16.42 Class 150 or BS EN1092-2 PN16 or GB/T9113.1
- Face to Face Standard: ASME B16.10
- Test Standard: UL262,ULC/ORD C262-92



HGO-200FF

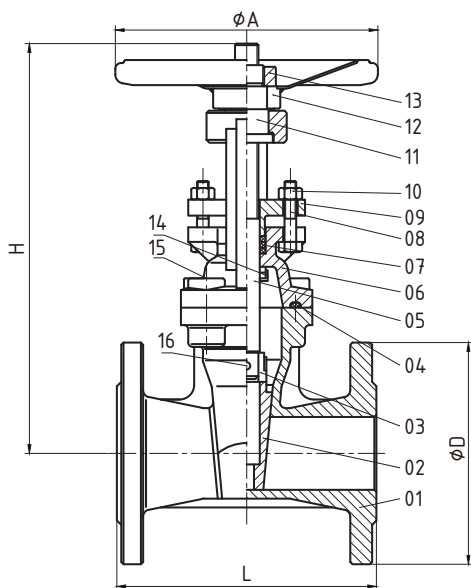

ITEM	PARTS	MATERIAL
1	BODY	DI ASTM A536 65-45-12
2	DISC	DI+EPDM ASTM A536 65-45-12 + EPDM
3	CONNECTING PART	C954 ASTM B148
4	SEALING PAD	EPDM ASTM D2000 EPDM
5	STEM	S.S.304 ASTM A276
6	CAP	DI ASTM A536 65-45-12
7	SEALING KITS	PTFE ASTM D4745
8	BOLT	STEEL
9	PLATEN	DI ASTM A536 65-45-12
10	NUT	STEEL
11	ROTATING NUT	C954 ASTM B148
12	HANDWHEEL	STEEL ANSI 1045
13	LOCK NET	STEEL ANSI 1045
14	FLAT KEY	STEEL
15	COUNTERSUNK HEAD BOLT	STEEL
16	CYLINDER PIN	STEEL

SIZES		DIMENSIONS (MM)			
Inch	mm	L	H	φD	φA
2"	DN 50	178	280	152	180
2-1/2"	DN 65	191	310	178	220
3"	DN 80	203	370	190	250
4"	DN 100	229	428	229	280
5"	DN 125	254	532	254	300
6"	DN 150	267	590	279	350
8"	DN 200	292	735	343	380
10"	DN 250	330	908	406	450
12"	DN 300	356	1150	483	450

HGO

series



UL O.S&Y Gate Valve – Grooved & Flange Ends

- Size: 2"(DN50) to 12"(DN300)
- Working Pressure: 200 PSI
- Test Pressure: 400 PSI
- Working Temp.: 0°C to 80°C (32°F to 176°F)
- Valve Standard: UL262,ULC/ORD C262-92
- Connection Standard:
 - Flange: ASME/ANSI B16.1 Class 125 or ASME/ANSI B16.42 Class 150 or BS EN1092-2 PN16 or GB/T9113.1
 - Grooved: ANSI/AWWA C606
- Face to Face Standard: ASME B16.10
- Test Standard: UL262,ULC/ORD C262-92



HGO-200FG

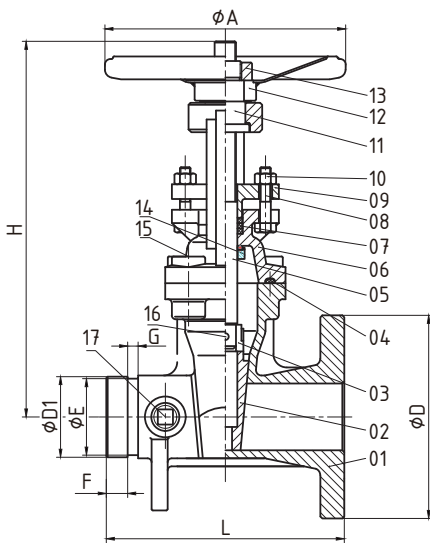

ITEM	PARTS	MATERIAL
1	BODY	DI ASTM A536 65-45-12
2	DISC	DI+EPDM ASTM A536 65-45-12 + EPDM
3	CONNECTING PART	C95400 ASTM B148
4	SEALING PAD	EPDM ASTM D2000 EPDM
5	STEM	S. S. 304 ASTM A276
6	CAP	DI ASTM A536 65-45-12
7	SEALING KITS	PTFE ASTM D4745
8	BOLT	STEEL
9	PLATEN	DI ASTM A536 65-45-12
10	NUT	STEEL ASTM A307 B
11	ROTATING NUT	C95400 ASTM B148
12	HANDWHEEL	STEEL ANSI 1045
13	LOCK NUT	STEEL ANSI 1045
14	FLAT KEY	STEEL
15	COUNTERSUNK HEAD BOLT	STEEL
16	CYLINDER PIN	STEEL
17	PLUG	C95400 ASTM B148

SIZES		DIMENSIONS (MM)							
Inch	mm	L	H	φD	φA	φD1	φE	F	G
2"	DN 50	178	313	152	180	60.3	57.2	15.9	7.9
2-1/2"	DN 65	190	340	178	200	76.1	72.3	15.9	7.9
3"	DN 80	203	387	191	220	88.9	84.9	15.9	7.9
4"	DN 100	229	440	229	250	114.3	110.1	15.9	9.5
5"	DN 125	254	546	254	280	141.3	137	15.9	9.5
6"	DN 150	267	607	279	300	168.3	163.9	15.9	9.5
8"	DN 200	292	786	343	350	219.1	214.4	19	11.1
10"	DN 250	330	946	406	406	273	268.3	19	12.7
12"	DN 300	356	1110	483	406	323.9	318.3	19	12.7

HGO

series



UL O.S&Y Gate Valve – Grooved Ends

- Size: 2"(DN50) to 12"(DN300)
- Working Pressure: 200 PSI
- Test Pressure: 400 PSI
- Working Temp.: 0°C to 80°C (32°F to 176°F)
- Valve Standard: UL262,ULC/ORD C262-92
- Connection Standard: ANSI/AWWA C606
- Face to Face Standard: ASME B16.10
- Test Standard: UL262,ULC/ORD C262-92



HGO-200GG

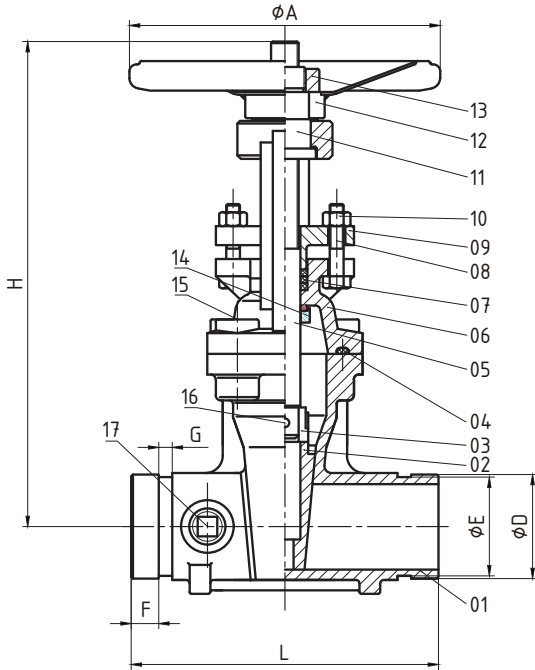

ITEM	PARTS	MATERIAL
1	BODY	DI ASTM A536 65-45-12
2	DISC	DI+EPDM ASTM A536 65-45-12 + EPDM
3	CONNECTING PART	C95400 ASTM B148
4	SEALING PAD	EPDM ASTM D2000 EPDM
5	STEM	S. S. 304 ASTM A276
6	CAP	DI ASTM A536 65-45-12
7	SEALING KITS	PTFE ASTM D4745
8	BOLT	STEEL ASTM A307 B
9	PLATEN	DI ASTM A536 65-45-12
10	NUT	STEEL
11	ROTATING NUT	C95400 ASTM B148
12	HANDWHEEL	STEEL ANSI 1045
13	LOCK NUT	STEEL ANSI 1045
14	FLAT KEY	S. S. 416 ASTM A276
15	COUNTERSUNK HEAD BOLT	STEEL
16	CYLINDER PIN	STEEL
17	PLUG	CAST BRONZE

SIZES		DIMENSIONS (MM)							
Inch	mm	L	H	φD	φA	φD	φE	F	G
2"	DN 50	178	313	152	180	60.3	57.2	15.9	7.9
2-1/2"	DN 65	190	340	178	200	76.1	72.3	15.9	7.9
3"	DN 80	203	387	191	220	88.9	84.9	15.9	7.9
4"	DN 100	229	440	229	250	114.3	110.1	15.9	9.5
5"	DN 125	254	546	254	280	141.3	137	15.9	9.5
6"	DN 150	267	607	279	300	168.3	163.9	15.9	9.5
8"	DN 200	292	786	343	350	219.1	214.4	19	11.1
10"	DN 250	330	946	406	406	273	268.3	19	12.7
12"	DN 300	356	1110	483	406	323.9	318.3	19	12.7

HGO

series



UL O.S&Y Gate Valve – Flange & Grooved Ends

- Size: 2.5"(DN65) to 12"(DN300)
- Working Pressure: 300 PSI
- Test Pressure: 600 PSI
- Working Temp.: 0°C to 80°C (32°F to 176°F)
- Valve Standard: UL262,ULC/ORD C262-92
- Connection Standard: Flange: ASME/ANSI B16.1 Class 125 or ASME/ANSI B16.42 Class 150 or BS EN1092-2 PN16 or GB/T9113.1
Grooved: ANSI/AWWA C606
- Face to Face Standard: ASME B16.10
- Test Standard: UL262,ULC/ORD C262-92



HGO-300FG

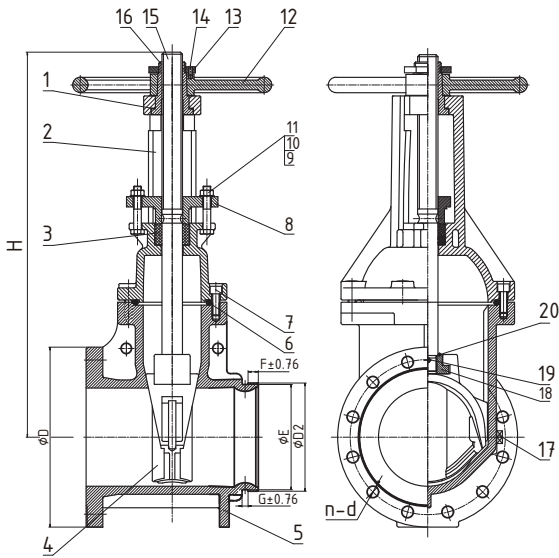

ITEM	PARTS	MATERIAL
1	GASKET	S. S. 304, ASTM A276 OR C95400, ASTM B148
2	BONNET	DI, ASTM A536 Grade 65-45-12
3	PACKING	GRAPHITE
4	DISC	DI, ASTM A536 Grade 65-45-12+EPDM, ASTM D2000
5	BODY	DI, ASTM A536 Grade 65-45-12
6	SEALING RING	EPDM, ASTM D2000
7	BOLT	S. S. 304, ASTM A276 OR1045, ASTM A29
8	GLAND	DI, ASTM A536 Grade 65-45-12
9	NUT	S. S. 304, ASTM A276 OR1045, ASTM A29
10	FLATWASHER	S. S. 304, ASTM A276 OR1045, ASTM A29
11	BOLT	S. S. 304, ASTM A276 OR1045, ASTM A29
12	HANDWHEEL	DI, ASTM A536 Grade 65-45-12
13	LOCK NUT	C95400, ASTM B148
14	LOCATING SCREW	S. S. 304, ASTM A276 OR1045, ASTM A29
15	STEM	S. S. 304, ASTM A276 OR C95400, ASTM B148
16	STEM NUT	C95400, ASTM B148
17	PLUG	C95400, ASTM B148
18	LIFTING NUT	CF8/CF8M, ASTM A351 OR C95400, ASTM B148
19	PIN	S. S. 304, ASTM A276
20	SEALING PING	EPDM, ASTM D2000

SIZES		DIMENSIONS (MM)								
Inch	mm	L	D	F	D2		E		G	H
2.5"	DN 65	190	178	15.9	76.1	73	72.3	69.1	7.9	370
3"	DN 80	203	191	15.9	88.9		84.9		7.9	420
4"	DN 100	229	229	15.9	114.3		110.1		9.5	447
5"	DN 125	254	254	15.9	141.3	139.7	137	135.5	9.5	547
6"	DN 150	267	279	15.9	168.3	165.1	163.9	160.8	9.5	607
8"	DN 200	292	343	19	219.1	216.3	214.3	211.6	11.1	754
10"	DN 250	330	406	19	273		268.3		12.7	890
12"	DN 300	356	483	19	323.9		318.3		12.7	1031

HGO

series



UL O.S&Y Gate Valve – Flange Ends

- Size: 2.5"(DN65) to 12"(DN300)
- Working Pressure: 300 PSI
- Test Pressure: 600 PSI
- Working Temp.: 0°C to 80°C (32°F to 176°F)
- Valve Standard: UL262,ULC/ORD C262-92
- Connection Standard: Flange: ASME/ANSI B16.1 Class 125 or ASME/ANSI B16.42 Class 150 or BS EN1092-2 PN16 or GB/T9113.1
- Face to Face Standard: ASME B16.10
- Test Standard: UL262,ULC/ORD C262-92



HGO-300FF

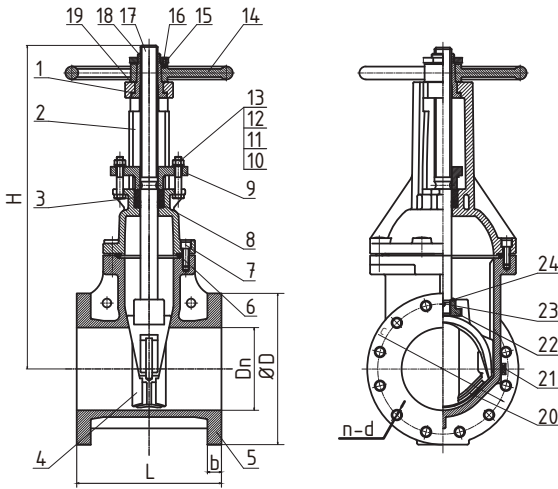

ITEM	PARTS	MATERIAL
1	GASKET	C28000
2	BONNET	DI
3	PACKING	PTFE
4	DISC	EPDM+DI
5	BODY	DI
6	SEALING RING	EPDM
7	BOLT	Steel
8	SEAL GASKET	EPDM
9	GLAND	DI
10	NUT	S. S. 304
11	FLAT WASHER	Steel
12	BOLT	S. S. 304
13	SPRING WASHER	Steel
14	HANDWHEEL	DI
15	LOCK NUT	C954
16	LOCATING SCREW	S. S. 304
17	STEM	S. S. 304
18	STEM NUT	C954
19	GASKET	C28000
20	SKELETON	DI
21	PLUG	C28000
22	LIFTING NUT	CF8M
23	PIN	S. S. 304
24	SEALING RING	EPDM

SIZES		DIMENSIONS (MM)					
Inch	mm	L	D	b	c	n-d	H
2.5	DN 65	190	178	17.5	139.5	4-Ø19	357
3	DN 80	203	191	21	152.5	4-Ø19	411
4	DN 100	229	229	24	190.5	8-Ø19	443
5	DN 125	254	254	23.9	216	8-Ø22	536
6	DN 150	267	279	25.4	241.5	8-Ø22	595
8	DN 200	292	343	28.6	298.5	8-Ø22	739
10	DN 250	330	406	30.2	362	12-Ø25	881
12	DN 300	356	483	31.8	432	12-Ø25	1021

HGO

series



UL O.S&Y Gate Valve – Grooved Ends

- Size: 2.5"(DN50) to 12"(DN300)
- Working Pressure: 300 PSI
- Test Pressure: 600 PSI
- Working Temp.: 0°C to 80°C (32°F to 176°F)
- Valve Standard: UL262,ULC/ORD C262-92
- Connection Standard: ANSI/AWWA C606
- Face to Face Standard: ASME B16.10
- Test Standard: UL262,ULC/ORD C262-92



HGO-300GG

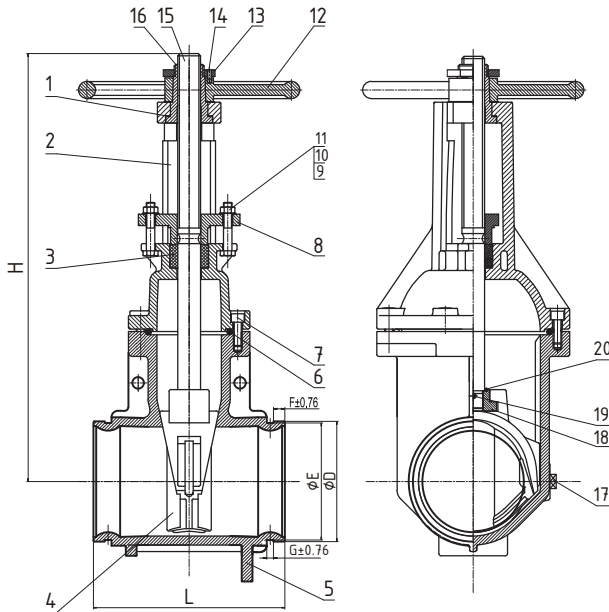

ITEM	PARTS	MATERIAL
1	GASKET	S.S.304, ASTM A276 OR C95400, ASTM B148
2	BONNET	DI, ASTM A536 Grade 65-45-12
3	PACKING	GRAPHITE
4	DISC	DI, ASTM A536 Grade 65-45-12 + EPDM,ASTM D2000
5	BODY	DI, ASTM A536 Grade 65-45-12
6	SEALING RING	EPDM,ASTM D2000
7	BOLT	S.S.304, ASTM A276 OR 1045, ASTM A29
8	GLAND	DI, ASTM A536 Grade 65-45-12
9	NUT	S.S.304, ASTM A276 OR 1045, ASTM A29
10	FLAT WASHER	S.S.304, ASTM A276 OR 1045, ASTM A29
11	BOLT	S.S.304, ASTM A276 OR 1045, ASTM A29
12	HANDWHEEL	DI, ASTM A536 Grade 65-45-12
13	LOCK NUT	C95400, ASTM B148
14	LOCATING SCREW	S.S.304, ASTM A276 OR 1045, ASTM A29
15	STEM	S.S.304, ASTM A276 OR C95400, ASTM B148
16	STEM NUT	C95400, ASTM B148
17	PLUG	C95400, ASTM B148
18	LIFTING NUT	CF8/CF8M, ASTM A351 OR C95400, ASTM B148
19	PIN	S.S.304, ASTM A276
20	SEALING RING	EPDM,ASTM D2000

SIZES		DIMENSIONS (MM)							
Inch	mm	L	F	D		E		G	H
2.5"	DN 65	190	15.9	76.1	73	72.3	69.1	7.9	370
3"	DN 80	203	15.9	88.9		84.9		7.9	420
4"	DN 100	229	15.9	114.3		110.1		9.5	447
5"	DN 125	254	15.9	141.3	139.7	137	135.5	9.5	547
6"	DN 150	267	15.9	168.3	165.1	163.9	160.8	9.5	607
8"	DN 200	292	19	219.1	216.3	214.3	211.6	11.1	754
10"	DN 250	330	19	273		268.3		12.7	890
12"	DN 300	356	19	323.9		318.3		12.7	1031

HCV

series



UL Swing Check Valve – Flange Ends

- Size: 2"(DN50) to 12"(DN300)
- Working Pressure: 300 PSI
- Test Pressure: 600 PSI
- Working Temp.: 0°C to 80°C (32°F to 176°F)
- Valve Standard: AWWA C508
- Connection Standard: ASME/ANSI B16.1 Class 125 or ASME/ANSI B16.42 Class 150 or BS EN1092-2 PN16 or GB/T9113.1
- Test Standard: UL312



HCV-300FF

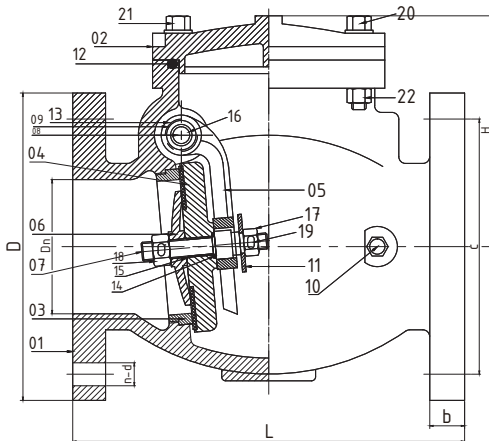

ITEM	PARTS	MATERIAL
1	BODY	ASTM A536 65-45-12
2	BONNET	ASTM A536 65-45-12
3	SEAT RING	ASTM A148 C95400
4	DISC	ASTM A536 65-45-12
5	ROCKER ARM	ASTM A536 65-45-12
6	BAFFLE PLATE	ASTM A536 65-45-12
7	MIDDLE STEM	ASTM A276 SS304
8	PINNED STEM	ASTM A276 SS304
9	BRACKET SCREW	ASTM A351 SS304
10	PLUG	ASTM A148 C95400
11	GASKET	ASTM A276 SS304
12	O-RING (LARGE)	ASTM D2000 EPDM
13	O-RING (FOR BRACKET SCREW)	ASTM D2000 EPDM
14	O-RING (FOR MID STEM)	ASTM D2000 EPDM
15	O-RING (FOR MID STEM 2)	ASTM D2000 EPDM
16	BRONZE BUSH	POWDER METALLURGY
17	SS304 OUTER HEXAGON NUT M12	ASTM A276 SS304
18	SS304 OUTER HEXAGON NUT M12	ASTM A276 SS304
19	SS304 COTTER PIN 4×55	ASTM A276 SS304
20	M12×60 ZINC OUTER HEXAGON BOLT(FALF THREAD)	ASTM A194 2H
21	M12×40 ZINC OUTER HEXAGON BOLT(FULL THREAD)	ASTM A194 2H
22	M12 ZINC OUTER HEXAGON NUT	ASTM A194 2H

SIZES		DIMENSIONS (MM)				
Inch	mm	L	D	C	N-D	H
2"	DN 50	203	152	120.5	4-φ19	142
2.5"	DN 65	216	178	139.5	4-φ19	148
3"	DN 80	241	191	152.5	4-φ19	163.5
4"	DN 100	292	229	190.5	8-φ19	172
5"	DN 125	330	254	216	8-φ19	237
6"	DN 150	356	279	241.5	8-φ19	233
8"	DN 200	495	343	298.5	8-φ19	301
10"	DN 250	622	406	362	12-φ19	348
12"	DN 300	698	483	432	12-φ19	419

HCV

series



UL Swing Check Valve – Flange Ends

- Size: 2"(DN50) to 12"(DN300)
- Working Pressure: 350 PSI
- Test Pressure: 700 PSI
- Working Temp.: 0°C to 80°C (32°F to 176°F)
- Valve Standard: AWWA C508
- Connection Standard: ASME/ANSI B16.1 Class 125 or ASME/ANSI B16.42 Class 150 or BS EN1092-2 PN16 or GB/T9113.1
- Test Standard: UL312



HCV-350FF

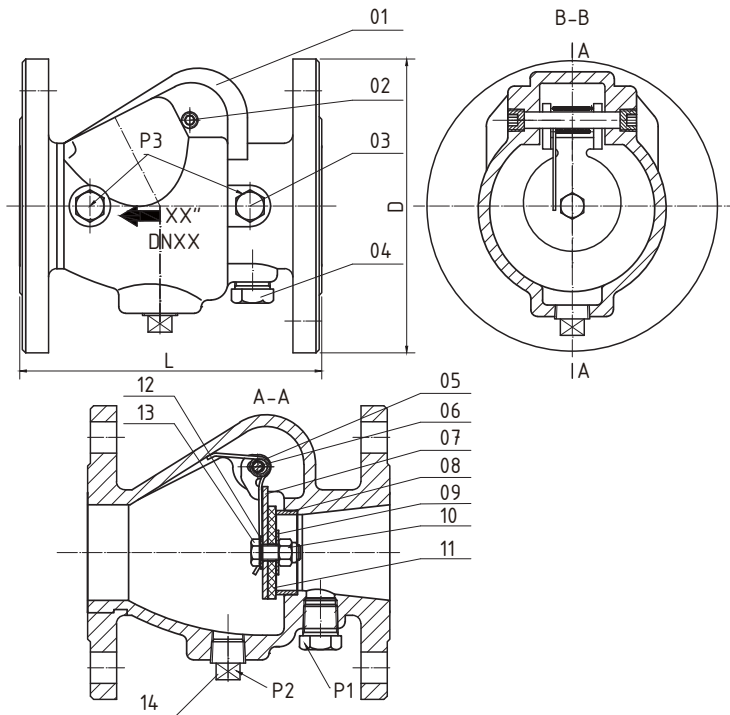

ITEM	PARTS	MATERIAL
1	VALVE BODY	A536 65-45-12
2	BOLT	STEEL
3	PLUG	STEEL
4	PLUG	STEEL
5	SPRING	304
6	HINGE PIN	304
7	CLAPPER	304
8	SEAT	C95400
9	CLAMPING RING	304
10	LOCKNUT	304
11	FACING SEAL	EPDM
12	GASKET	EPDM
13	BOLT	304
14	PLUG	STEEL

SIZES		DIMENSIONS (MM)											
Inch	mm	L	D	P1		P2					P3		
2"	DN 50	169	152	1/2-14NPT	1/2-14NPT	3/4-14NPT	1-11. 5NPT	1 1/4-11. 5NPT	2-11. 5NPT	1/4-18NPT	3/8-18NPT	1/2-14NPT	
2.5"	DN 65	181	178	1/2-14NPT	1/2-14NPT	3/4-14NPT	1-11. 5NPT	1 1/4-11. 5NPT	2-11. 5NPT	1/4-18NPT	3/8-18NPT	1/2-14NPT	
3"	DN 80	198	191	1/2-14NPT	1/2-14NPT	3/4-14NPT	1-11. 5NPT	1 1/4-11. 5NPT	2-11. 5NPT	1/4-18NPT	3/8-18NPT	1/2-14NPT	
4"	DN 100	214	229	1/2-14NPT	1/2-14NPT	3/4-14NPT	1-11. 5NPT	1 1/4-11. 5NPT	2-11. 5NPT	1/4-18NPT	3/8-18NPT	1/2-14NPT	
5"	DN 150	248	254	1/2-14NPT	1/2-14NPT	3/4-14NPT	1-11. 5NPT	1 1/4-11. 5NPT	2-11. 5NPT	1/4-18NPT	3/8-18NPT	1/2-14NPT	
6"	DN 125	270	280	1/2-14NPT	1/2-14NPT	3/4-14NPT	1-11. 5NPT	1 1/4-11. 5NPT	2-11. 5NPT	1/4-18NPT	3/8-18NPT	1/2-14NPT	
8"	DN 200	325	343	1/2-14NPT	1/2-14NPT	3/4-14NPT	1-11. 5NPT	1 1/4-11. 5NPT	2-11. 5NPT	1/4-18NPT	3/8-18NPT	1/2-14NPT	

HCV

series



UL Swing Check Valve – Flange & Grooved Ends

- Size: 2"(DN50) to 12"(DN300)
- Working Pressure: 350 PSI
- Test Pressure: 700 PSI
- Working Temp.: 0°C to 80°C (32°F to 176°F)
- Valve Standard: UL312
- Connection Standard:
 - Inlet Flange: ASME/ANSI B16.1 Class 125 or ASME/ANSI B16.42 Class 150 or BS EN1092-2 PN16 or GB/T9113.1
 - Outlet Grooved: ANSI/AWWA C606
- Test Standard: UL312



HCV-350FG

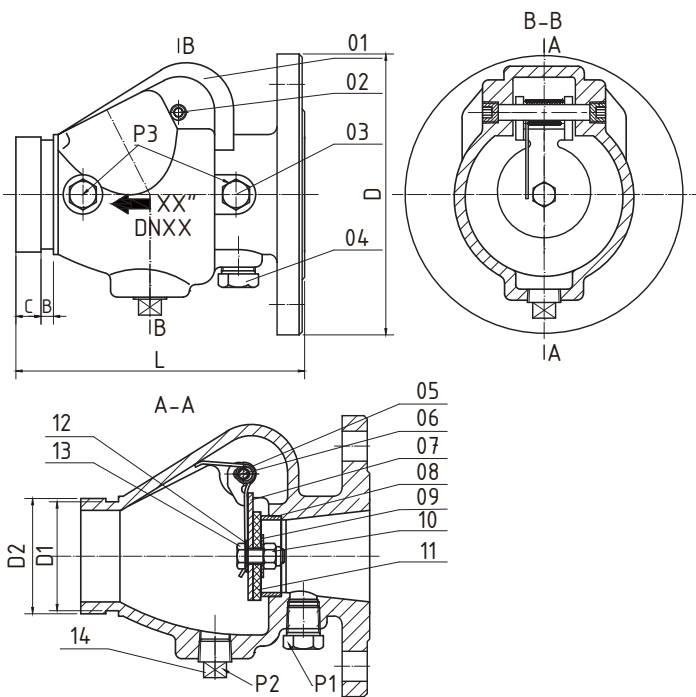

ITEM	PARTS	MATERIAL
1	VALVE BODY	A536 65-45-12
2	BOLT	STEEL
3	PLUG	STEEL
4	PLUG	STEEL
5	SPRING	304
6	HINGE PIN	304
7	CLAPPER	304
8	SEAT	C95400
9	CLAMPING RING	304
10	LOCKNUT	304
11	FACING SEAL	EPDM
12	GASKET	EPDM
13	BOLT	304
14	PLUG	STEEL

SIZES		DIMENSIONS (MM)																	
Inch	mm	L	D	D1	D2	B	C	P1	P2					P3					
2"	DN 50	169	152	57.15	60.3	7.95	15.88	1/2-14NPT	1/2-14NPT	3/4-14NPT	1-11.5NPT	1 1/4-11.5NPT	1 1/2-11.5NPT	2-11.5NPT	1/4-18NPT	3/8-18NPT	1/2-14NPT		
2.5"	DN 65	181	178	69.09	72.26	7.95	15.88	1/2-14NPT	1/2-14NPT	3/4-14NPT	1-11.5NPT	1 1/4-11.5NPT	1 1/2-11.5NPT	2-11.5NPT	1/4-18NPT	3/8-18NPT	1/2-14NPT		
3"	DN 80	198	191	84.94	88.9	7.95	15.88	1/2-14NPT	1/2-14NPT	3/4-14NPT	1-11.5NPT	1 1/4-11.5NPT	1 1/2-11.5NPT	2-11.5NPT	1/4-18NPT	3/8-18NPT	1/2-14NPT		
4"	DN 100	214	229	110.08	114.3	9.53	15.88	1/2-14NPT	1/2-14NPT	3/4-14NPT	1-11.5NPT	1 1/4-11.5NPT	1 1/2-11.5NPT	2-11.5NPT	1/4-18NPT	3/8-18NPT	1/2-14NPT		
5"	DN 125	248	254	135.48	137.03	139.7	141.3	9.53	15.88	1/2-14NPT	1/2-14NPT	3/4-14NPT	1-11.5NPT	1 1/4-11.5NPT	1 1/2-11.5NPT	2-11.5NPT	1/4-18NPT	3/8-18NPT	1/2-14NPT
6"	DN 150	270	280	160.78	163.96	165.1	168.1	9.53	15.88	1/2-14NPT	1/2-14NPT	3/4-14NPT	1-11.5NPT	1 1/4-11.5NPT	1 1/2-11.5NPT	2-11.5NPT	1/4-18NPT	3/8-18NPT	1/2-14NPT
8"	DN 200	325	343	211.6	214.4	216.3	219.1	11.13	19.05	1/2-14NPT	1/2-14NPT	3/4-14NPT	1-11.5NPT	1 1/4-11.5NPT	1 1/2-11.5NPT	2-11.5NPT	1/4-18NPT	3/8-18NPT	1/2-14NPT

HCV

series



UL Swing Check Valve –Grooved & Flange Ends

- Size: 2"(DN50) to 12"(DN300)
- Working Pressure: 350 PSI
- Test Pressure: 700 PSI
- Working Temp.: 0°C to 80°C (32°F to 176°F)
- Valve Standard: UL312
- Connection Standard:
 - Outlet Flange: ASME/ANSI B16.1 Class 125 or ASME/ANSI B16.42 Class 150 or BS EN1092-2 PN16 or GB/T9113.1
 - Inlet Grooved: ANSI/AWWA C606
- Test Standard: UL312



HCV-300GF

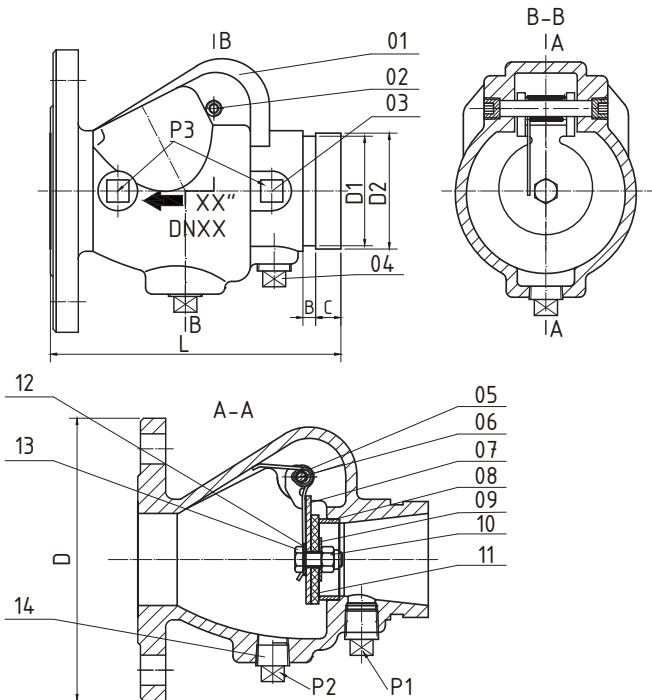

ITEM	PARTS	MATERIAL
1	VALVE BODY	A536 65-45-12
2	BOLT	STEEL
3	PLUG	STEEL
4	PLUG	STEEL
5	SPRING	304
6	HINGE PIN	304
7	CLAPPER	304
8	SEAT	C95400
9	CLAMPING RING	304
10	LOCKNUT	304
11	FACING SEAL	EPDM
12	GASKET	EPDM
13	BOLT	304
14	PLUG	STEEL

SIZES		DIMENSIONS (MM)																	
Inch	mm	L	D	D1	D2	B	C	P1	P2					P3					
2"	DN 50	169	152	57.15	60.3	7.95	15.88	1/2-14NPT	1/2-14NPT	3/4-14NPT	1-11.5NPT	1 1/4-11.5NPT	1 1/2-11.5NPT	2-11.5NPT	1/4-18NPT	3/8-18NPT	1/2-14NPT		
2.5"	DN 65	181	178	69.09	72.26	7.95	15.88	1/2-14NPT	1/2-14NPT	3/4-14NPT	1-11.5NPT	1 1/4-11.5NPT	1 1/2-11.5NPT	2-11.5NPT	1/4-18NPT	3/8-18NPT	1/2-14NPT		
3"	DN 80	198	191	84.94	88.9	7.95	15.88	1/2-14NPT	1/2-14NPT	3/4-14NPT	1-11.5NPT	1 1/4-11.5NPT	1 1/2-11.5NPT	2-11.5NPT	1/4-18NPT	3/8-18NPT	1/2-14NPT		
4"	DN 100	214	229	110.08	114.3	9.53	15.88	1/2-14NPT	1/2-14NPT	3/4-14NPT	1-11.5NPT	1 1/4-11.5NPT	1 1/2-11.5NPT	2-11.5NPT	1/4-18NPT	3/8-18NPT	1/2-14NPT		
5"	DN 125	248	254	135.48	137.03	139.7	141.3	9.53	15.88	1/2-14NPT	1/2-14NPT	3/4-14NPT	1-11.5NPT	1 1/4-11.5NPT	1 1/2-11.5NPT	2-11.5NPT	1/4-18NPT	3/8-18NPT	1/2-14NPT
6"	DN 150	270	280	160.78	163.96	165.1	168.1	9.53	15.88	1/2-14NPT	1/2-14NPT	3/4-14NPT	1-11.5NPT	1 1/4-11.5NPT	1 1/2-11.5NPT	2-11.5NPT	1/4-18NPT	3/8-18NPT	1/2-14NPT
8"	DN 200	325	343	211.6	214.4	216.3	219.1	11.13	19.05	1/2-14NPT	1/2-14NPT	3/4-14NPT	1-11.5NPT	1 1/4-11.5NPT	1 1/2-11.5NPT	2-11.5NPT	1/4-18NPT	3/8-18NPT	1/2-14NPT

HCV

series



UL Swing Check Valve – Grooved Ends

- Size: 2"(DN50) to 12"(DN300)
- Working Pressure: 350 PSI
- Test Pressure: 700 PSI
- Working Temp.: 0°C to 80°C (32°F to 176°F)
- Valve Standard: UL312
- Connection Standard: ANSI/AWWA C606
- Test Standard: UL312



HCV-350GG

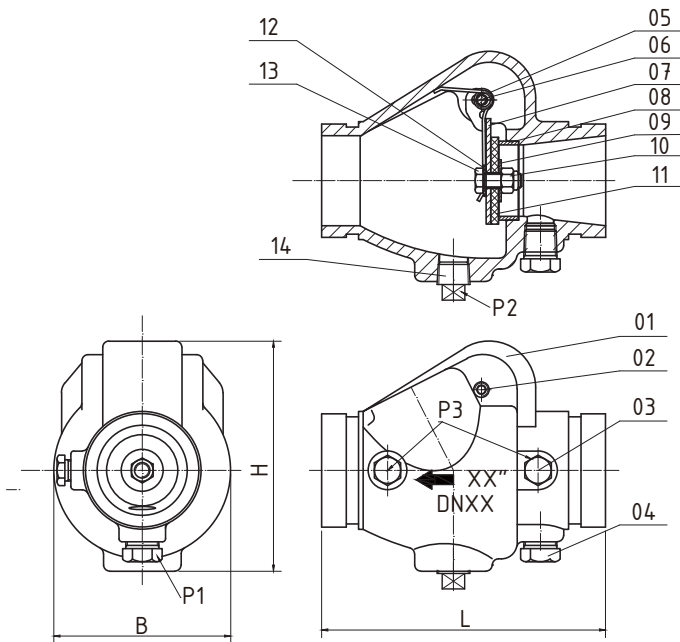

ITEM	PARTS	MATERIAL
1	VALVE BODY	A536 65-45-12
2	BOLT	STEEL
3	PLUG	STEEL
4	PLUG	STEEL
5	SPRING	304
6	HINGE PIN	304
7	CLAPPER	304
8	SEAT	C95400
9	CLAMPING RING	304
10	LOCKNUT	304
11	FACING SEAL	EPDM
12	GASKET	EPDM
13	BOLT	304
14	PLUG	STEEL

SIZES		DIMENSIONS (MM)													
Inch	mm	B	H	L	P1			P2					P3		
2"	DN 50	100	131	169	1/2-14NPT	1/2-14NPT	3/4-14NPT	1-11.5NPT	1 1/4-11.5NPT	1 1/2-11.5NPT	2-11.5NPT	1/4-18NPT	3/8-18NPT	1/2-14NPT	
2.5"	DN 65	104	141	181	1/2-14NPT	1/2-14NPT	3/4-14NPT	1-11.5NPT	1 1/4-11.5NPT	1 1/2-11.5NPT	2-11.5NPT	1/4-18NPT	3/8-18NPT	1/2-14NPT	
3"	DN 80	128	166	198	1/2-14NPT	1/2-14NPT	3/4-14NPT	1-11.5NPT	1 1/4-11.5NPT	1 1/2-11.5NPT	2-11.5NPT	1/4-18NPT	3/8-18NPT	1/2-14NPT	
4"	DN 100	151	195	214	1/2-14NPT	1/2-14NPT	3/4-14NPT	1-11.5NPT	1 1/4-11.5NPT	1 1/2-11.5NPT	2-11.5NPT	1/4-18NPT	3/8-18NPT	1/2-14NPT	
5"	DN 125	189	223	248	1/2-14NPT	1/2-14NPT	3/4-14NPT	1-11.5NPT	1 1/4-11.5NPT	1 1/2-11.5NPT	2-11.5NPT	1/4-18NPT	3/8-18NPT	1/2-14NPT	
6"	DN 150	220	252	270	1/2-14NPT	1/2-14NPT	3/4-14NPT	1-11.5NPT	1 1/4-11.5NPT	1 1/2-11.5NPT	2-11.5NPT	1/4-18NPT	3/8-18NPT	1/2-14NPT	
8"	DN 200	279	303	325	1/2-14NPT	1/2-14NPT	3/4-14NPT	1-11.5NPT	1 1/4-11.5NPT	1 1/2-11.5NPT	2-11.5NPT	1/4-18NPT	3/8-18NPT	1/2-14NPT	

ELITE LINE INDUSTRIAL CORPORATION

No.40,Jialing Street. Cianjhen District, Kaohsiung City, Taiwan

Tel: +886-7-3311060 Fax: +886-7-3310100

E-mail: sales@z-tide.com

www.z-tide.com





VLM77.EX15524 - Special System Water Control Valves, Pressure-reducing and Pressure-control Type Certified for Canada

Special System Water Control Valves, Pressure-reducing and Pressure-control Type Certified for Canada

See [General Information for Special System Water Control Valves, Pressure-reducing and Pressure-control Type Certified for Canada](#)

Z-TIDE VALVES INDUSTRIAL CO LTD

41 Sec 2 New Taipei Blvd
Sanchong District
New Taipei, 241 TAIWAN

EX15524

Pilot-operated pressure-control valve, Model UL-BFR, in ductile iron body, consisting of the following sizes and pressures:

Model	Body Type	Size, NPS	Max Rated Inlet Pressure (kPa)	Outlet Pressure Setting Range (kPa)
UL-BFR	Globe	3, 4, 6 and 8	2068	206-689

Class 150 flanges are intended to be installed on systems not exceeding 1724 kPa.

The manufacturer's design and installation instructions, dated 2018-10-03, include a description of the performance characteristics for both flow and static conditions.

Trademark and/or Tradename:

Last Updated on 2018-12-03

The appearance of a company's name or product in this database does not in itself assure that products so identified have been manufactured under UL's Follow-Up Service. Only those products bearing the UL Mark should be considered to be Certified and covered under UL's Follow-Up Service. Always look for the Mark on the product.

UL permits the reproduction of the material contained in the Online Certification Directory subject to the following conditions: 1. The Guide Information, Assemblies, Constructions, Designs, Systems, and/or Certifications (files) must be presented in their entirety and in a non-misleading manner, without any manipulation of the data (or drawings). 2. The statement "Reprinted from the Online Certifications Directory with permission from UL" must appear adjacent to the extracted material. In addition, the reprinted material must include a copyright notice in the following format: "© 2021 UL LLC"



VLMT.EX15524 - Special System Water Control Valves, Pressure-reducing and Pressure-control Type

Special System Water Control Valves, Pressure-reducing and Pressure-control Type

See [General Information for Special System Water Control Valves, Pressure-reducing and Pressure-control Type](#)

Z-TIDE VALVES INDUSTRIAL CO LTD

41 Sec 2 New Taipei Blvd
Sanchong District
New Taipei, 241 TAIWAN

EX15524

Pilot-operated pressure-control valve, Model UL-BFR, in ductile iron body, consisting of the following sizes and pressures:

Model	Body Type	Size, NPS	Max Rated Inlet Pressure (psig)	Outlet Pressure Setting Range (psig)
UL-BFR	Globe	3, 4, 6 and 8	300	30-100

Class 150 flanges are intended to be installed on systems not exceeding 250 psig.

The manufacturer's design and installation instructions, dated 2018-10-03, include a description of the performance characteristics for both flow and static conditions.

Trademark and/or Tradename:

[Last Updated](#) on 2018-12-03

The appearance of a company's name or product in this database does not in itself assure that products so identified have been manufactured under UL's Follow-Up Service. Only those products bearing the UL Mark should be considered to be Certified and covered under UL's Follow-Up Service. Always look for the Mark on the product.

UL permits the reproduction of the material contained in the Online Certification Directory subject to the following conditions: 1. The Guide Information, Assemblies, Constructions, Designs, Systems, and/or Certifications (files) must be presented in their entirety and in a non-misleading manner, without any manipulation of the data (or drawings). 2. The statement "Reprinted from the Online Certifications Directory with permission from UL" must appear adjacent to the extracted material. In addition, the reprinted material must include a copyright notice in the following format: "© 2021 UL LLC"

HBOR.EX28077 - HYDRANTS

Hydrants

See General Information for Hydrants

HANTS CONTROL CORP

40,JIALING ST.,CIANJIHEN DISTRICT
 KAOHSIUNG, 80656 TAIWAN

Base-valve design:

Model	Base-valve Size, in.	Hose Outlet (No. of Outlets), in.	Pumper Outlet (No. of Outlets), in.	Rated Pressure, psig
HHY-250MJ	5-1/4	(2) 2-1/2	(1) 4-1/2	250
HHY-250FF	5-1/4	(2) 2-1/2	(1) 4-1/2	250

EX28077

Last Updated on 2019-04-16

The appearance of a company's name or product in this database does not in itself assure that products so identified have been manufactured under UL's Follow-Up Service. Only those products bearing the UL Mark should be considered to be Certified and covered under UL's Follow-Up Service. Always look for the Mark on the product.

UL permits the reproduction of the material contained in the Online Certification Directory subject to the following conditions: 1. The Guide Information, Assemblies, Constructions, Designs, Systems, and/or Certifications (files) must be presented in their entirety and in a non-misleading manner, without any manipulation of the data (or drawings). 2. The statement "Reprinted from the Online Certifications Directory with permission from UL" must appear adjacent to the extracted material. In addition, the reprinted material must include a copyright notice in the following format: "© 2019 UL LLC"



VEHZ.EX28069 - DRAIN FITTINGS, SPECIAL TYPE

Drain Fittings, Special Type

See General Information for Drain Fittings, Special Type

HANTS CONTROL CORP
40,JIALING ST.,CIANJHEN DISTRICT
KAOSIUNG, 80656 TAIWAN

EX28069

Model HTD7 threaded test and drain fitting in the following nominal sizes, discharge coefficients and rated pressures:

Size, in.	Nominal K-Factor, gpm/(psi) ^{1/2}	Rated Pressure, psig
1, 1-1/4	4.2, 5.6	300
1-1/2, 2	4.2, 5.6, 14.0, 25.2	

Model HTD8 threaded test and drain fitting in the following nominal sizes, discharge coefficients and rated pressures:

Size, in.	Nominal K-Factor, gpm/(psi) ^{1/2}	Rated Pressure, psig
1, 1-1/4	4.2, 5.6	300
1-1/2, 2	4.2, 5.6, 14.0, 25.2	

Last Updated on 2019-05-13

The appearance of a company's name or product in this database does not in itself assure that products so identified have been manufactured under UL's Follow-Up Service. Only those products bearing the UL Mark should be considered to be Certified and covered under UL's Follow-Up Service. Always look for the Mark on the product.

UL permits the reproduction of the material contained in the Online Certification Directory subject to the following conditions: 1. The Guide Information, Assemblies, Constructions, Designs, Systems, and/or Certifications (files) must be presented in their entirety and in a non-misleading manner, without any manipulation of the data (or drawings). 2. The statement "Reprinted from the Online Certifications Directory with permission from UL" must appear adjacent to the extracted material. In addition, the reprinted material must include a copyright notice in the following format: "© 2019 UL LLC"



HMRZ.EX27768 - GATE VALVES

Gate Valves

See General Information for Gate Valves

HANTS CONTROL CORP
40 JIALING ST., CIANJIHEN DISTRICT
KAOSIUNG, 80656 TAIWAN

EX27768

Model	Type	Size, in.	Rated Pressure, psig	Rated Pressure, psig	End Configuration
HGO-300FF	O.S&Y	2.5,3,4,5,6,8,10,12	300		Flange & Flange
HGN-300FF	NRS	2.5,3,4,5,6,8,10,12	300		Flange & Flange
HGO-FF	O.S&Y	2,2.5,3,4,5,6,8,10,12	200		Flange & Flange
HGO-FG					Flange & Grooved
HGO-GG					Grooved & Grooved
HGN-FF	NRS	2.5,3,4,5,6,8,10,12	200		Flange & Flange
HGN-FG					Flange & Grooved
HGN-GG					Grooved & Grooved
HGO-200FF	O.S&Y	2,2.5,3,4,5,6,8,10,12	200		Flange & Flange
HGO-200FG					Flange & Grooved
HGO-200GG					Grooved & Grooved
HGN-200FF	NRS	2.5,3,4,5,6,8,10,12	200		Flange & Flange
HGN-200FG					Flange & Grooved
HGN-200GG					Grooved & Grooved

Note: O.S&Y, outside-screw-and-yoke type NRS, nonrising stem type.

Flanges comply with ANSI B16.1 Class 125; for 300 psi, use Face flange, for 200 psi, use Raised-face flange.

Trademark and/or Tradename:

Last Updated on 2019-07-08

The appearance of a company's name or product in this database does not in itself assure that products so identified have been manufactured under UL's Follow-Up Service. Only those products bearing the UL Mark should be considered to be Certified and covered under UL's Follow-Up Service. Always look for the Mark on the product.

UL permits the reproduction of the material contained in the Online Certification Directory subject to the following conditions: 1. The Guide Information, Assemblies, Constructions, Designs, Systems, and/or Certifications (files) must be presented in their entirety and in a non-misleading manner, without any manipulation of the data (or drawings). 2. The statement "Reprinted from the Online Certifications Directory with permission from UL" must appear adjacent to the extracted material. In addition, the reprinted material must include a copyright notice in the following format: "© 2019 UL LLC"



HMER.EX27769 - CHECK VALVES

Check Valves

See General Information for Check Valves

HANTS CONTROL CORP

40,JIALING ST.,CIANJIEN DISTRICT
KAOHSIUNG, 80656 TAIWAN

EX27769

Model	Type	Valve Seat Facing	Nom Pipe Size, NPS	End Config	Rated Pressure, psig	Installation Position
HCV-300FF	Swing	Elastomeric	2, 2-1/2, 3, 4, 5, 6, 8, 10, 12	F by F	300	H, V
HCV-350GG	Swing	Elastomeric	2, 2-1/2, 3, 4, 5, 6, 8	G by G	350	H
HCV-350FF	Swing	Elastomeric	2, 2-1/2, 3, 4, 5, 6, 8	F by F	350	H
HCV-350FG	Swing	Elastomeric	2, 2-1/2, 3, 4, 5, 6, 8	F by G	350	H
HCV-350GF	Swing	Elastomeric	2, 2-1/2, 3, 4, 5, 6, 8	G by F	350	H

End Configuration:

F - Flanged

G - Grooved

Installation Position:

H - Horizontal installation

V - Vertical installation

Trademark and/or Tradename:

Last Updated on 2019-07-08

The appearance of a company's name or product in this database does not in itself assure that products so identified have been manufactured under UL's Follow-Up Service. Only those products bearing the UL Mark should be considered to be Certified and covered under UL's Follow-Up Service. Always look for the Mark on the product.

UL permits the reproduction of the material contained in the Online Certification Directory subject to the following conditions: 1. The Guide Information, Assemblies, Constructions, Designs, Systems, and/or Certifications (files) must be presented in their entirety and in a non-misleading manner, without any manipulation of the data (or drawings). 2. The statement "Reprinted from the Online Certifications Directory with permission from UL" must appear adjacent to the extracted material. In addition, the reprinted material must include a copyright notice in the following format: "© 2019 UL LLC"



HLXS.EX27767 - BUTTERFLY VALVES

Butterfly Valves

See General Information for Butterfly Valves

HANT'S CONTROL CORP
40, JIALING ST., CIANJHEN DISTRICT
KAOHSIUNG, 80656 TAIWAN

EX27767

Model	Size, NPS	Body Type	Pressure Rating, psig (Bar)	Indicator Post	Supervisory Switch*
Butterfly valve					
HBF-300G	2, 2.5(76.1mm), 3, 4, 5 (139.7 mm), 6, 6 (165.1 mm)	Groove	300	—	I/O
	8, 8 (216.3 mm), 10, 10 (267.4 mm)				
	12, 12 (318.4 mm)				
HBF-300W	2, 2.5, 3, 4, 5, 6	Wafer	300	—	I/O
	8, 10				
	12				
HBF-300MG	10, 12	Wafer	300	—	I/O
HBF-300WW	10, 10(267.4mm), 12, 12(318.4mm)	Groove	300	—	I/O
HBB-300FG	2.5, 2.5(76.1 mm), 3, 4, 6 (165.1mm), 8, 8(216.3mm), 10, 10(267.4mm)	F by G	300	—	I/O
HBB-175FG	2.5, 2.5(76.1 mm), 3, 4, 6 (165.1mm), 8, 8(216.3mm), 10, 10(267.4mm)	F by G	175	—	I/O
HBB-300GG	2.5, 2.5(76.1 mm), 3, 4, 6 (165.1mm), 8, 8(216.3mm), 10, 10(267.4mm)	Groove	300	—	I/O
	2.5, 2.5(76.1 mm), 3, 4, 6 (165.1mm), 8, 8(216.3mm), 10, 10(267.4mm)				

Note: F-Flange, G-Groove

* I = Indoor installation; O = Outdoor installation

Last Updated on 2019-07-08

The appearance of a company's name or product in this database does not in itself assure that products so identified have been manufactured under UL's Follow-Up Service. Only those products bearing the UL Mark should be considered to be Certified and covered under UL's Follow-Up Service. Always look for the Mark on the product.

UL permits the reproduction of the material contained in the Online Certification Directory subject to the following conditions: 1. The Guide Information, Assemblies, Constructions, Designs, Systems, and/or Certifications (files) must be presented in their entirety and in a non-misleading manner, without any manipulation of the data (or drawings). 2. This statement "Reprinted from the Online Certifications Directory with permission from UL" must appear adjacent to the extracted material. In addition, the reprinted material must include a copyright notice in the following format: "© 2019 UL LLC"